



RESIDENTIAL REPLACEMENT PARTS LIST

Residential Programmable Efficiency (PE) Models



PE2XR504*F(BN,SX)
PE4403S*F(BN,SX)
PE4503S*F(BN,SX)
PE440T*F(BN,SX)

DEFENDER
SAFETY SYSTEM®

Includes Hydrojet®
Total Performance System

Effective: February, 2010
ECO 7508

NOTE: BOTH MODEL AND SERIAL
NUMBERS ARE REQUIRED FOR
ORDERING REPLACEMENT PARTS

Dimensions and specifications
subject to change without notice.

Item	Description	Model	Model	Model	Model
		PE2XR504T*F(BN,SX)	PE4403S*F(BN,SX)	PE440T*F(BN,SX)	PE4503*F(BN,SX)
1	Heat Trap Insert (Outlet)	239-45167-00	239-45167-00	239-45167-00	239-45167-00
2	Hot Water Outlet Anode Magnesium ▲	224-47776-12	224-47776-05	224-47776-17	224-47776-12
	Aluminum ▲	224-32999-21	224-32999-10	224-32999-24	224-32999-21
	A420 Aluminum ▲	224-45147-04	224-45147-03	224-45147-02	224-45147-04
3	Setback Junction Box Assembly	239-47649-00	239-47649-00	239-47649-00	239-47649-00
4	Baffle	243-41037-00	243-45223-00	243-42283-00	243-44705-00
5	Accessory Module	239-47873-00	239-47873-00	239-47873-00	239-47873-00
6	Harness-2 Wire Intermediate Acc. Module	239-48235-00	239-48235-00	239-48235-00	239-48235-00
7	Harness-Plug in Transformer	239-48428-00	239-48428-00	239-48428-00	239-48428-00
8	Harness-Setback Control A	239-47653-00	239-47653-00	239-47653-00	239-47653-00
9	Harness-Setback Control B	239-47654-00	239-47654-00	239-47654-00	239-47654-00
10	Harness-Setback Control Junction Box	239-47652-02	239-47652-01	239-47652-02	239-47652-02
11	Flammable Vapor Sensor	239-45560-00	239-45560-00	239-45560-00	239-45560-00
12	Flammable Vapor Sensor Clip	239-45648-00	239-45648-00	239-45648-00	239-45648-00
13	Brass Drain Valve	265-42351-02	265-42351-02	265-42351-02	265-42351-02
14	Thermal Well	233-45651-02	233-45651-02	233-45651-02	233-45651-02
15	Gas Control Service Tool	239-45991-00	239-45991-00	239-45991-00	239-45991-00
16	Gas Control (Natural Gas)	239-45613-01	239-45613-01	239-45613-01	239-45613-01
	Gas Control (LP Gas)	239-45614-01	239-45614-01	239-45614-01	239-45614-01
17	Sensor Harness	243-47906-00	243-47906-00	243-47906-00	243-47906-00
18	Left Side Inner Door	239-43968-18	239-43968-18	239-43968-16	239-43968-18
19	Outer Door	243-43962-00	243-43962-00	243-43962-00	243-43962-00
20	Screw-#8-32 X.50 Semi-Gimlet	239-36860-00	239-36860-00	239-36860-00	239-36860-00
21	Switch-Thermal Re-settable	239-43676-02	239-43676-02	239-43676-03	239-43676-02
22	Right Side Inner Door (Complete)	239-43963-07	239-43963-07	239-43963-05	239-43963-07
23	Pipe Plug-3/4" NPT Square Socket	239-11638-00	239-11638-00	239-11638-00	239-11638-00
24	T&P Relief Valve	230-40594-02	230-40594-02	230-40594-02	230-40594-02
25	Cold Water Inlet Dip Tube Polypropylene ▲▲	229-39625-18	229-39625-03	229-39625-25	229-39625-22
	Cold Water Inlet Dip Tube Polysulfone ▲▲	229-39628-18	229-39628-03	229-39628-28	229-39628-21
26	Heat Trap Insert (Inlet)	239-45073-00	239-45073-00	239-45073-00	239-45073-00
27	Draft Diverter	243-33081-02-20	243-45787-00	243-45787-00	243-45787-00
28	Kit-Heat trap insert	265-45419-00	265-45419-00	265-45419-00	265-45419-00
29	ASSE Approved Mixing Valve (Optional)	239-43740-01	239-43740-01	239-43740-01	239-43740-01
30	Inner Door Gasket Kit	239-44078-00	239-44078-00	239-44078-00	239-44078-00

*Applies to all warranties

**Inner door gasket kit recommended

***Ordering a complete burner assembly may increase delivery time. Please order the specific component required for the quickest delivery.

▲ Order with item 1

▲▲ Order with item 26

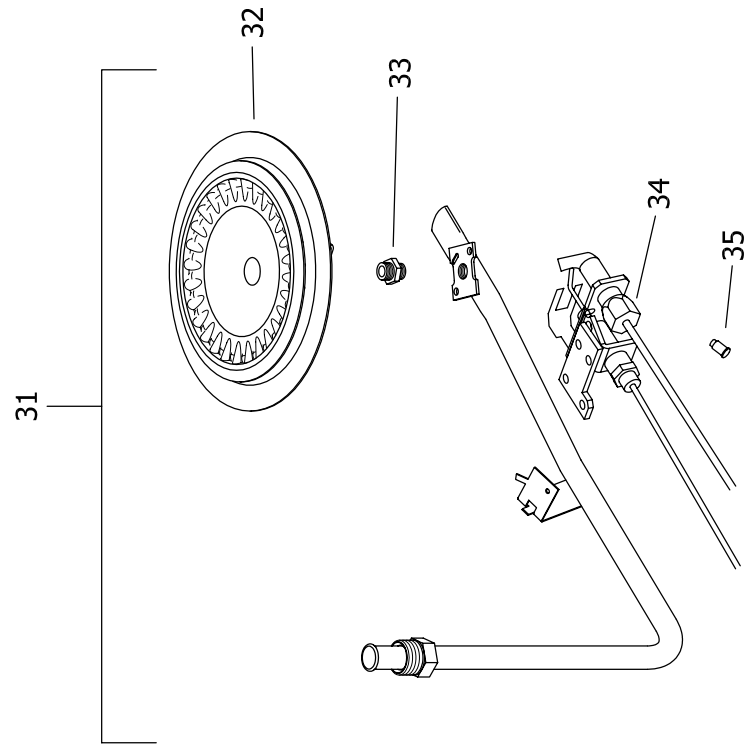

NATURAL GAS (BN)
BURNER ASSEMBLY

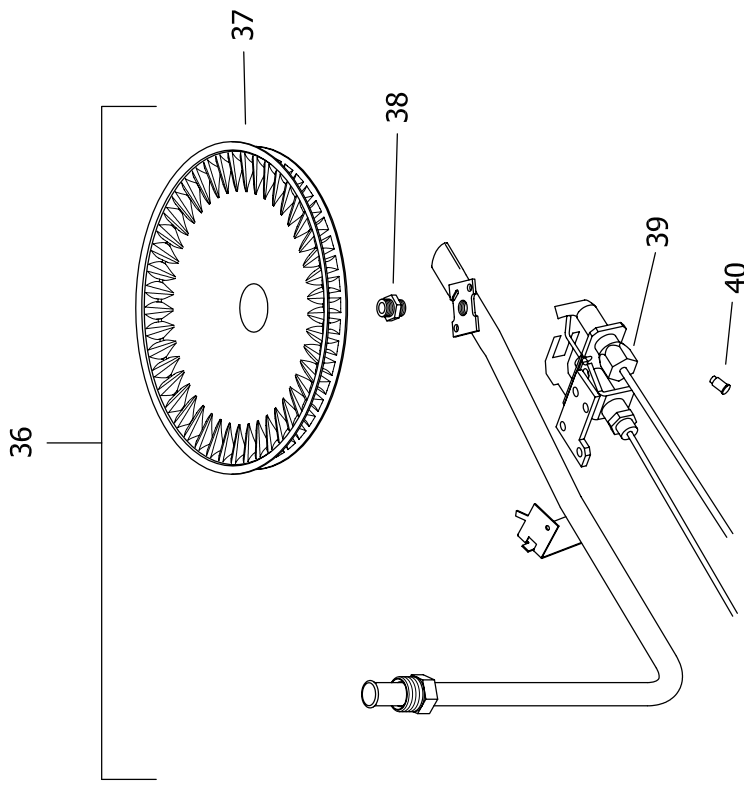

LP GAS (SX)
BURNER ASSEMBLY

Item Description	Model	Model	Model	Model
	PE2XR504T*F(BN,SX)	PE4403S*F(BN,SX)	PE440T*F(BN,SX)	PE4503*F(BN,SX)
Natural Gas (BN) Burner Assembly				
31 Nat. Gas (BN) Burner Assembly Complete***	265-47439-06-27	265-47439-06-32	265-47439-16-32	265-47439-06-32
32 Nat. Gas (BN) Burner**	228-42506-00	228-42506-00	228-42506-00	228-42506-00
33 Nat. Gas (BN) Main Burner Orifice**	234-41034-27	234-41034-32	234-41034-32	234-41034-32
Nat. Gas (BN) High Altitude 2001 Ft. to 5000 Ft.**	234-41034-29	234-41034-36	234-41034-36	234-41034-36
Nat. Gas (BN) High Altitude 5001 Ft. to 8000 Ft.**	234-41034-30	234-41034-38	234-41034-38	234-41034-38
Nat. Gas (BN) High Altitude Over 8000 Ft.**	234-41034-31	234-41034-38	234-41034-38	234-41034-38
34 Nat. Gas Pilot Assembly**	233-45653-05	233-45653-05	233-45653-05	233-45653-05
35 Nat. Gas Pilot Orifice**	234-45869-01	234-45869-01	234-45869-01	234-45869-01
LP Gas (SX) Titanium Stabilized Stainless Steel Burner Assembly				
36 LP Gas (SX) Burner Assembly Complete***	265-47440-10-43	265-47440-09-50	265-47440-25-50	265-47440-09-51
37 LP Gas (SX) Burner**	228-47000-00	228-46964-00	228-46964-00	228-46964-00
38 LP Gas (SX) Main Burner Orifice**	234-47064-43	234-47064-50	234-47064-52	234-47064-51
LP Gas (SX) High Altitude 2001 Ft. to 5000 Ft.**	234-47064-46	234-47064-51	234-47064-53	234-47064-52
LP Gas (SX) High Altitude 5001 Ft. to 8000 Ft.**	234-47064-47	234-47064-52	234-47064-54	234-47064-53
LP Gas (SX) High Altitude Over 8000 Ft.**	234-47064-47	234-41034-53	234-47064-54	234-47064-54
39 LP Gas Pilot Assembly**	233-45653-04	233-45653-04	233-45653-04	233-45653-04
40 LP Gas Pilot Orifice**	234-45869-02	234-45869-02	234-45869-02	234-45869-02
- LP to Natural Gas Conversion Kit (Norm Alt.)	265-46493-63	265-46493-64	265-46493-65	265-46493-66
- LP to Natural Gas Conversion Kit (High Alt.)	265-46493-67	265-46493-68	265-46493-69	265-46493-70

*Applies to all warranties

**Inner door gasket kit recommended

***Ordering a complete burner assembly may increase delivery time. Please order the specific component required for the quickest delivery.

▲ Order with item 1

▲▲ Order with item 26



BRADFORD WHITE®

W A T E R H E A T E R S

Ambler, PA

For U.S. and Canada field service,
contact your professional installer or
local Bradford White sales representative.

Sales/800-523-2931
Fax/215-641-1670
Parts Fax/215-641-2180

Technical Support/800-334-3393
Fax/269-795-1089

Warranty/800-531-2111
Fax/269-795-1089

International:
Telephone/215-641-9400
Telefax/215-641-9750



BRADFORD WHITE-CANADA® INC.

Mississauga, ON

Sales/866-690-0961
905-238-0100

Fax/905-238-0105

Technical Support/800-334-3393

Email

parts@bradfordwhite.com
techserv@bradfordwhite.com

www.bradfordwhite.com