



Residential Energy Saver Gas-Upright (M-4)



Photo is of
M-4-40T6FBN

The M-4 FVIR Defender Safety System® Models Feature:

- **Advanced ScreenLok® Technology Flame Arrestor Design**—Flame arrestor is designed to prevent ignition of flammable vapor outside of the water heater.
- **Resettable Thermal Switch**—Proven and reliable bimetallic switch prevents burner and pilot operation in case of ongoing flammable vapor burn inside of the combustion chamber or restricted air flow.
- **Piezo Igniter**—Easy and quick lighting of the pilot burner by push button.
- **Pedestal Base**—Rugged and durable base allows easy transport and positioning, corrosion resistant contact with floor.
- **Maintenance Free**—No regular cleaning of air inlet openings or flame arrestor is required under normal conditions.
- **Sight Window**—Offers a view into the combustion chamber to observe the operation of the pilot and burner.
- **MEETS C.E.C. TITLE 24, SCAQMD Rule 1121 (40ng/J).**
- **DOE**—All residential storage models meet or exceed efficiency requirements of the Department of Energy. ASHRAE Standard 90.1 b (current standard) and the National Appliance Energy Conservation Act of 1987 recent amendment effective January 20, 2004 which supercedes all state and local efficiency requirements.
- **2" Non-CFC Foam Insulation**—Surrounds the tank surface, saving energy by retarding loss of heat. No added insulation blanket required to meet C.E.C. Title 24, Section 2-5352 requirements.
- **Flue Baffle**—Designed to maximize the amount of heat absorbed in the lower portion of tank. Minimizes air movement in the heater during standby periods to retard heat loss up the flue.
- **Fully Automatic Controls**—Automatic temperature selection at your fingertips. Built-in energy cut-off switch prevents abnormally high water temperature for extra safety. Built-in gas pressure regulation.
- **Vitraglas® Lining**—Bradford White water heater tanks are protected from the corrosive effects of hot water by an exclusive ceramic porcelain-like coating. The Bradford White high silica Vitraglas® lining provides a tough interior surface for our hot water tanks.
- **Protective Magnesium Anode Rod**—Provides added protection against corrosion for long trouble-free service.
- **Factory Installed Hydrojet® Total Performance System**—Cold water inlet sediment reducing device. Helps prevent sediment build up in tank. Increases first hour delivery of hot water while minimizing temperature build up at top of tank.
- **Factory Installed Heat Traps**—Design incorporates a flexible disk that reduces heat loss in piping and eliminates the potential for noise generation.
- **Water Connections**—3/4" NPT factory installed true dielectric fittings. Extends water heater life and eases installation.
- **Brass Drain Valve.**
- **3x4 "Snap Lock" Draft Diverter**—Allows either 3" or 4" vent connections with inputs of 40,000 BTU/Hr or less.
- **T&P Relief Valve Included**—All sizes come standard with special tapping on side of tank. (Optional top T&P valve available. Please see reverse side for dimensions).
- **Steel Tank**—Heavy gauge steel automatically formed, rolled and welded to assure a continuous seam for glass lining.
- **Design Certified by CSA International (formerly AGA/CGA).**



6 or 10-Year Limited Tank Warranties / 6-Year Limited Warranty on Component Parts.

For more information on warranty, please visit www.bradfordwhite.com

For products installed in USA, Canada and Puerto Rico. Some states do not allow limitations on warranties. See complete copy of the warranty included with the heater.

Bradford White received the highest numerical score among water heater/boiler manufacturers in the proprietary J.D. Power and Associates/ McGraw-Hill Construction 2006 HVAC and Water Heater/Boiler Subcontractor Satisfaction Study™. Study based on 882 responses measuring 3 water heater/boiler manufacturers and measures opinions of subcontractors. Proprietary study results are based on experiences and perceptions of subcontractors surveyed in May through July 2006. Your experiences may vary. Visit jdpower.com

MANUFACTURED UNDER ONE OR MORE OF THE FOLLOWING U.S. PATENTS: 7,063,133 B2; 5,954,492; 5,954,492; 5,761,379; 5,943,984; 5,081,696; 5,988,117; 6,142,216; 5,199,385; 5,574,822; 5,372,185; 5,485,879; 5,277,171; (B1)5,341,770; 5,660,165; 5,596,952; 5,682,666; 4,904,428; 5,023,031; 5,000,893; 4,669,448; 4,829,983; 4,808,356; 5,115,767; 5,092,519; 5,052,346; 4,416,222; 4,628,184; 4,861,968; 4,672,919; Re. 34,534. OTHER U.S. AND FOREIGN PATENT APPLICATIONS PENDING. CURRENT CANADIAN PATENTS: 1,272,914; 1,280,043; 1,289,832; 2,045,862; 2,112,515; 2,108,186; 2,107,012; 2,092,105. Defender Safety System®, ScreenLok®, Vitraglas® and Hydrojet® are registered trademarks of Bradford White® Corporation. ©2006, Bradford White Corporation. All rights reserved. Printed in U.S.A.

Residential Energy Saver Gas-Upright



M-4 Series Energy Saver Models

NATURAL GAS AND LIQUID PROPANE GAS

Meet or exceed ASHRAE 90.1b (current standard) C.E.C. Listed
79% Recovery Efficiency

Model Number	Capacity		Recovery* 90°F Rise				A Floor to Flue Conn. in.	B Jacket Dia. in.	C Vent Size in.	D Floor to T&P Conn. in.	E Floor to Gas Conn. in.	F Floor to Water Conn. in.	Approx. Shipping Weight lbs.		
	U.S. Gal.	Imp. Gal.	Nat. BTU/Hr. Input	LP BTU/Hr. Input	Nat. U.S. GPH	LP U.S. GPH									
M-4-30T6FBN ●	30	25	32,000	31,000	34	28	33	27	59 ¹ / ₈	18	3x4	49 ³ / ₄ / 56 ³ / ₈	13	57 ¹ / ₂	114
M-4-40T6FBN ●	40	33	40,000	36,000	43	36	38	32	59 ³ / ₈	20	3x4	50 / 56 ⁵ / ₈	13	57 ³ / ₄	128
M-4-40S6FBN ●	40	33	40,000	38,000	43	36	40	33	50	22	3x4	41 / 47 ¹ / ₄	13	48 ¹ / ₂	133
M-4-50S6FBN ●	50	42	40,000	36,000	43	36	38	32	59 ³ / ₈	22	3x4	50 / 57	13	58	151
M-4-60T6FBN	60	50	40,000	38,000	43	36	40	33	60 ³ / ₄	24	3x4	50 ¹ / ₂	13	58 ¹ / ₄	192

Model Number	Capacity		Recovery* 50°C Rise				A Floor to Flue Conn. mm.	B Jacket Dia. mm.	C Vent Size mm.	D Floor to T&P Conn. mm.	E Floor to Gas Conn. mm.	F Floor to Water Conn. mm.	Approx. Shipping Weight kg.
	Liters		Nat. kW Input	LP kW Input	Nat. Liters/Hour	LP Liters/Hour							
M-4-30T6FBN ●	114		9.4	9.1	129	125	1502	457	76x102	1264 / 1432	330	1460	52
M-4-40T6FBN ●	151		11.7	10.5	163	144	1508	508	76x102	1270 / 1438	330	1467	58
M-4-40S6FBN ●	151		11.7	11.1	163	151	1270	559	76x102	1041 / 1200	330	1232	60
M-4-50S6FBN ●	189		11.7	10.5	163	144	1514	559	76x102	1270 / 1448	330	1473	68
M-4-60T6FBN	227		11.7	11.1	163	151	1543	609	76x102	1282	330	1480	87

All propane heaters are equipped with a cast iron burner. To order a propane heater change suffix "BN" to "CX". For 10 year models, change suffix from "6" to "10".

*Based on manufacturers rated recovery efficiency.

- Models feature optional top T&P location and must be specified when ordering (M-4-60T does not have top T&P option).

"D" dimension listed as side/top.

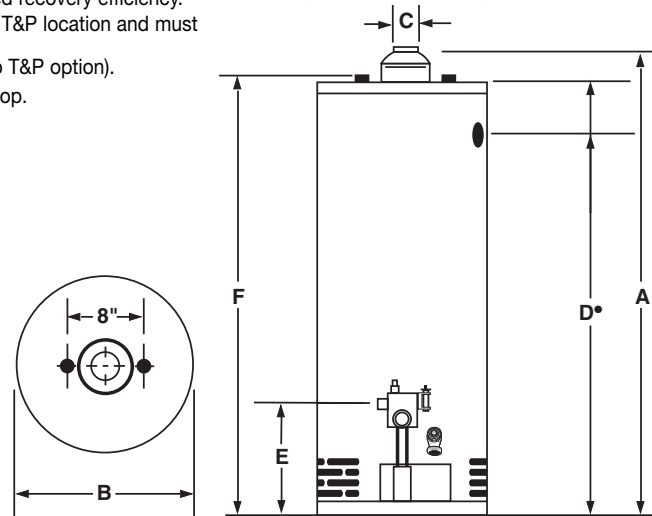

All natural gas models meet SCAQMD Requirements.
Meets NAECA Requirements

General

All gas water heaters are certified at 300 PSI (2068 kPa) test pressure and 150 PSI (1034 kPa) working pressure.

All water connections are 3/4" (19mm) NPT on 8" (203 mm) centers. All gas connections are 1/2" (13mm).

All models design certified by CSA International (formerly AGA/CGA), ANSI Z-21.10.1 and peak performance rated.

Dimensions and specifications subject to change without notice in accordance with our policy of continuous product improvement.

Suitable for Water (Potable) Heating and Space Heating

Toxic chemicals, such as those used for boiler treatment, shall NEVER be introduced into this system. This unit may NEVER be connected to any existing heating system or component(s) previously used with a non-potable water heating appliance.



Ambler, PA

For U.S. and Canada field service, contact your professional installer or local Bradford White sales representative.

Sales 800-523-2931 • Fax 215-641-1670 / Technical Support 800-334-3393 • Fax 269-795-1089 • Warranty 800-531-2111 • Fax 269-795-1089

International: Telephone 215-641-9400 • Telefax 215-641-9750 / Fax on Demand 888-538-7833 / www.bradfordwhite.com

BRADFORD WHITE - CANADA INC. Sales / Technical Support 866-690-0961 / 905-238-0100 • Fax 905-238-0105 / www.bradfordwhitecanada.com

Count On Bradford White
For *Everything* Hot Water™

©2006, Bradford White Corporation. All rights reserved.