

TTW²

Residential Power Vent Energy Saver Gas Water Heater



Photo is of
M-2-TW-50T6FBN

The TTW² FVIR Defender Safety System[®] Models Feature (50 and 65 gallon models, only):

- **ENERGY STAR[®] Qualified**—These models qualify for the January 1st, 2009 minimum ENERGY STAR[®] EF requirement, as well as most utility rebate programs.
- **Advanced ScreenLok[®] Technology Flame Arrestor Design**—Flame arrestor is designed to prevent ignition of flammable vapor outside of the water heater.
- **Flammable Vapor Sensor**—Electronic sensor prevents burner operation if flammable vapors are detected. The sensor will also prevent operation if there is ongoing flammable vapor burn inside the combustion chamber.
- **Maintenance Free**—No regular cleaning of air inlet openings or flame arrestor is required under normal conditions.
- **Sight Window**—Offers a view into the combustion chamber to observe the operation of the pilot and burner.

All TTW² Models Feature:

- **Powerful Blower Motor**—Our significantly quiet design has greater resistance to outside winds and the power to vent in many difficult venting situations.
- **Factory Installed Hydrojet[®] 2[™] Total Performance System**—Cold water inlet sediment reducing device helps prevent sediment build up in tank. Increases first hour delivery of hot water while minimizing temperature build up at top of tank.
- **Vitraglas[®] Lining**—Bradford White tanks are lined with an exclusively engineered enamel formula that provides superior tank protection from the highly corrosive effects of hot water. This formula (Vitraglas[®]) is fused to the steel surface by firing at a temperature of over 1600° F.
- **Honeywell Self Diagnostic Electronic Gas Control**—Intelligent gas control with spark to pilot ignition system eliminates the constant burning pilot. This results in savings of pilot gas during stand by periods (120 V.A.C.).
 - **Enhanced Performance**—Proprietary algorithms provide enhanced First Hour Delivery ratings and tighter temperature differentials.
 - **Advanced Temperature Control System**—Microprocessor constantly monitors and controls burner operation to maintain accurate and consistent water temperature levels.
 - **Intelligent Diagnostics**—An exclusive green LED light prompts the installer during start-up and provides ten different diagnostic codes to assist in troubleshooting.
 - **Pilot On Indication**—Flashing green LED provides positive indication that pilot is on.
- **Horizontal and Vertical Venting**—With 3" or 4" PVC, ABS or CPVC (Maximum equivalent vent length on reverse side).
- **2" Non-CFC Foam Insulation**—Covers the sides and top of tank to save energy by retarding loss of heat. Also increases jacket rigidity.
- **Water Connections**—3/4" NPT factory installed true dielectric fittings.
- **Factory Installed Heat Traps**—Design incorporates a flexible disk that reduces heat loss in piping and eliminates the potential for noise generation.
- **Protective Magnesium Anode Rod.**
- **3/4" NPT Side Connections.**
- **Pedestal Base.**
- **T&P Relief Valve**—Included.
- **Brass Drain Valve**—Durable tamper proof design.



6 or 10-Year Limited Tank Warranties / 6-Year Limited Warranty on Component Parts.

For more information on warranty, please visit www.bradfordwhite.com

For products installed in USA, Canada and Puerto Rico. Some states do not allow limitations on warranties. See complete copy of the warranty included with the heater.

Residential Power Vent Gas Water Heater



TTW® 2 Energy Saver Models

NATURAL GAS AND LIQUID PROPANE GAS

Meet or exceed ASHRAE 90.1b (current standard) C.E.C. Listed
80% Recovery Efficiency

Model Number	Capacity		Nat. BTU/Hr. Input	LP BTU/Hr. Input	Recovery 90°F Rise*				A Floor to Vent Conn. in.	B Jacket Dia. in.	C Vent Size in.	D Floor to T&P Conn. in.	E Floor to Gas Conn. in.	F Floor to Space Heating Return in.	G Floor to Space Heating Outlet in.	H Floor to Heater Top in.	J Floor to Water Conn. in.	K Depth in.	Approx. Shipping Weight lbs.
	U.S. Gal.	Imp. Gal.			Nat. U.S. GPH	Nat. Imp. GPH	LP U.S. GPH	LP Imp. GPH											
M-2-TW-50T6FBN	48	40	67,000	60,000	72	60	65	54	65%	22	3	50%	11%	13%	50%	56%	57%	26%	188
M-2-TW-65T6FBN	65	54	70,000	63,000	75	63	68	56	69	24	3	53½	11%	13½	53½	59%	60%	28%	222
M-2-TW-75T6BN	75	62	76,000	75,500	82	68	81	67	68%	26	3	53	15	17%	53	60%	61%	31	257

Model Number	Capacity		Nat. kW Input	LP kW Input	Recovery 50°C Rise*		A Floor to Vent Conn. mm.	B Jacket Dia. mm.	C Vent Size mm.	D Floor to T&P Conn. mm.	E Floor to Gas Conn. mm.	F Floor to Space Heating Return mm.	G Floor to Space Heating Outlet mm.	H Floor to Heater Top mm.	J Floor to Water Conn. mm.	K Depth mm.	Approx. Shipping Weight kg.
	Liters				Nat. Liters/Hour	LP Liters/Hour											
M-2-TW-50T6FBN	182		19.6	17.6	273	245	1673	560	76	1273	298	343	1273	1432	1467	679	85
M-2-TW-65T6FBN	246		20.5	18.5	285	257	1753	610	76	1360	298	343	1360	1511	1543	730	101
M-2-TW-75T6BN	284		22.3	22.1	310	306	1737	660	76	1346	381	451	1346	1530	1562	787	117

Propane models feature a Titanium Stainless Steel propane burner. For Propane (LP) models change suffix "BN" to "SX".
For 10 year models, change suffix from "6" to "10".

*Based on manufacturer's rated recovery efficiency.
110 V.A.C. Required for Power Venting / 110 V.A.C. 60HZ 3.1 Amperes.
M-2-TW-75T does not qualify for ENERGY STAR®.

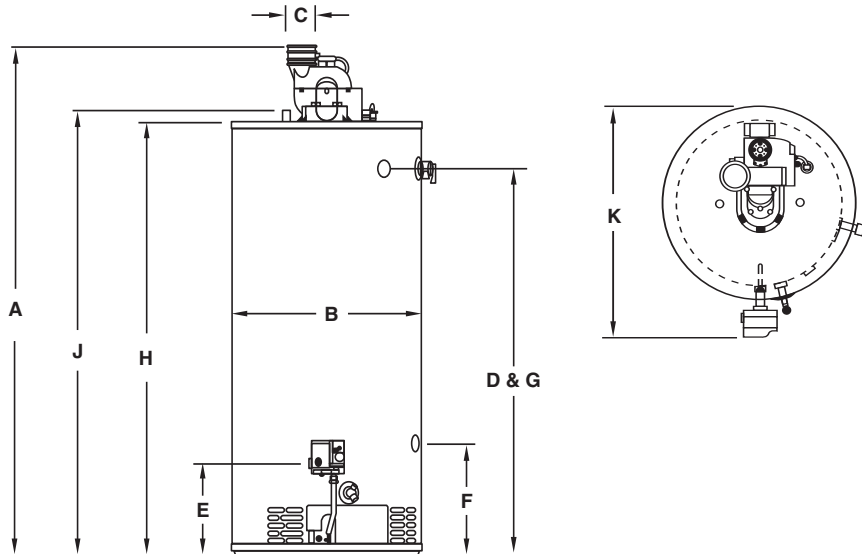

	3" Vent Pipe	4" Vent Pipe
M-2-TW50		
M-2-TW65		
M-2-TW75		
Max. Equivalent Length	†60 ft.**	†180 ft.
Min. Equivalent Length	7 ft.	15 ft.
Number of 90° Elbows	1: 55 ft. 2: 50 ft. 3: 45 ft.	175 ft. 170 ft. 165 ft.

Subtract 5ft. for each additional 90° elbow
† For high altitude installations, consult the installation instructions.

**M-2-TW75 Max. 3" vent length is 50ft.

Meets NAECA Requirements

General

All gas water heaters are certified at 300 PSI (2068 kPa) test pressure and 150 PSI (1034 kPa) working pressure.
All water connections are 3/4" NPT (19mm) on 11" (279mm) centers, all gas connections are 1/2" (13mm).
All models design certified by CSA International (formerly AGA/CGA), ANSI Z-21.10.1 and/or 10.3 and peak performance rated.

Dimensions and specifications subject to change without notice in accordance with our policy of continuous product improvement.

Suitable for Water (Potable) Heating and Space Heating

Toxic chemicals, such as those used for boiler treatment, shall NEVER be introduced into this system. This unit may NEVER be connected to any existing heating system or component(s) previously used with a non-potable water heating appliance.



For U.S. and Canada field service, contact your professional installer or local Bradford White sales representative.

Sales 800-523-2931 • Fax 215-641-1670 / Technical Support 800-334-3393 • Fax 269-795-1089 • Warranty 800-531-2111 • Fax 269-795-1089

International: Telephone 215-641-9400 • Telefax 215-641-9750 / www.bradfordwhite.com

BRADFORD WHITE-CANADA INC. Sales / Technical Support 866-690-0961 / 905-238-0100 • Fax 905-238-0105 / www.bradfordwhite.com

Built to be the Best™

©2009, Bradford White Corporation. All rights reserved.