

Commercial Induced Draft Energy Saver Gas Water Heater



Photo is of
D-65T-625-3NA

The Induced Draft Models feature:

- **Honeywell Integrated Control**—Intelligent proven design combines temperature control, diagnostic codes, and system ignition functions into a single control board with a digital LCD display. Control panel cover tilts down for ease of wiring and service.
- **Operation Mode**—Two different digitally displayed operation modes have the capability of adjusting the temperature setting up to 180°F (82°C), and adjusting the degree setting (°F to °C, or °C to °F).
- **Service Mode**—Eight different digitally displayed service modes can be easily cycled through by pressing the select button. There is the capability of adjusting the temperature setting up to 180°F (82°C), adjusting the degree setting (°F to °C, or °C to °F), locking the maximum temperature setting that can be adjusted in operation mode, displaying the average water temperature (if water heater has two sensors), displaying the upper temperature sensor, displaying the lower temperature sensor, displaying the flame current of the pilot flame, and displaying diagnostic codes.
- **Electronic Ignition**—High voltage, low current electricity is sent to the pilot electrode initiating a spark to ignite the pilot gas. This results in savings of pilot gas during stand-by periods because the pilot flame only operates when there's a call for heat.
- **Automatic Flue Damper**—Reduces stand-by loss, saving gas consumption and improving overall efficiency.
- **Factory Installed Hydrojet[®] Total Performance System**—Cold water inlet sediment reducing device helps prevent sediment build up in tank. Increases first hour delivery of hot water while minimizing temperature build up in tank.
- **Vitraglas[®] Lining**—Bradford White tanks are lined with an exclusively engineered enamel formula that provides superior tank protection from the highly corrosive effects of hot water. This formula (Vitraglas[®]) is fused to the steel surface by firing at a temperature of over 1600°F.
- **2" Non-CFC Foam Insulation**—Covers the sides and top of tank, reducing the amount of heat loss. This results in less energy consumption, improved operation efficiencies and jacket rigidity.
- **Potable Water Connections**—1½" NPT factory installed true dielectric fittings extend water heater life and eases installation.
- **Protective Magnesium Anode Rods**—Provide added protection against corrosion for long trouble-free service.
- **Hand Hole Cleanout**—Allows inspection of tank interior and removal of sediment deposits.
- **E.C.O.**—An automatic re-set Energy Cut Off (E.C.O) shuts off all gas in event of an overheat condition. This automatically re-sets when operation conditions are back to normal.
- **Sanitizing Capability**—Temperature setting up to 180°F (82°C).
- **NSF Construction Available.**
- **ASME Code Available.**
- **T&P Relief Valve**—Installed.
- **Brass Drain Valve**—Tamper proof.
- **Design Certified by CSA International (Formerly AGA and CGA).**



3-Year Limited Tank Warranties / 1-Year Limited Warranty on Component Parts.

For more information on warranty, please visit www.bradfordwhite.com

For products installed in USA, Canada and Puerto Rico. Some states do not allow limitations on warranties. See complete copy of the warranty included with the heater.

Commercial Gas Water Heater

Induced Draft Energy Saver Models

NATURAL GAS AND LIQUID PROPANE GAS

Meet or exceed ASHRAE 90.1b (current standard) C.E.C. Listed
80% Recovery Efficiency

Model Number	Capacity		Nat. & LP BTU/Hr. Input	First Hr. Del. Rating @ 100°F Rise	GPH Recovery* at Degree Rise			A	B	C	D	E	F	G	Gas Conn.	Relief Valve Open	Approx. Shipping Weight lbs.	Approx. Shipping Weight lbs.
	U.S. Imp. Gal.	Gal.			40°F	100°F	140°F	in.	in.	in.	in.	in.	in.	in.				
D-65T-625-3N(A)	65	54	625,000	651	1515	606	433	69 ³ / ₈	28 ¹ / ₄	8	54 ¹ / ₈	28 ⁷ / ₈	10 ¹ / ₂	68 ⁷ / ₈	1†	1	720	775
D-80T-725-3N(A)	80	66	725,000	759	1757	703	502	79 ⁵ / ₈	28 ¹ / ₄	8	64 ¹ / ₄	28 ⁷ / ₈	10 ¹ / ₂	79 ¹ / ₈	1†	1	800	880

Model Number	Capacity		Nat. & LP kW Input	First Hr. Del. Rating @ 56°C Rise	GPH Recovery* at Degree Rise			A	B	C	D	E	F	G	Gas Conn.	Relief Valve Open	Approx. Shipping Weight kg.	Approx. Shipping Weight kg.
	U.S. Imp. Gal.	Gal.			22°C	56°C	78°C	mm.	mm.	mm.	mm.	mm.	mm.	mm.				
D-65T-625-3N(A)	246	183	183	2464	5734	2294	1638	1762	724	203	1375	733	267	1749	25†	25	326	352
D-80T-725-3N(A)	303	212.3	212.3	2873	6652	2661	1901	2022	724	203	1632	733	267	2010	25†	25	363	399

*Recoveries and First Hour Delivery Ratings are based on Natural Gas input and 80% Thermal Efficiency.

For Propane(LP) Gas Models change suffix "N" to "X".

†LP Gas Connection 3/4" (76 mm).

(A)=ASME Construction Available.

For 5 year models, change suffix "3" to "5".

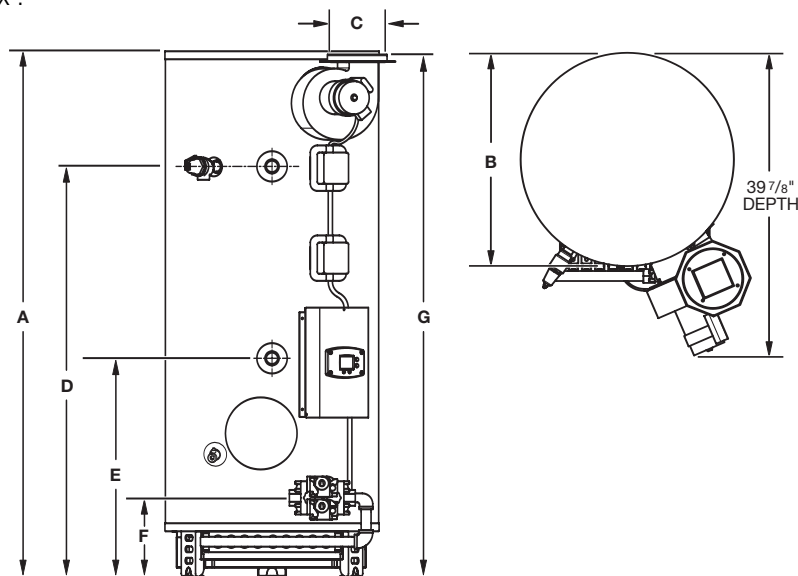

Sample Specification

The water heater shall be a Bradford White model with a rated storage capacity of not less than _____ gallons (_____ liters), a minimum gas input of _____ BTU/hr. (_____ kW), a minimum recovery of _____ GPH (_____ LPH), and a minimum First Hour Delivery of _____ Gal. (_____ liters). The tank shall be Vitraglas® lined and have a bolted hand hole cleanout. A digital LCD display shall be integrated into the front control box, and the control shall be an adjustable electronic thermostat to any temperature up to 180°F (82°C), and must have an automatic re-set Energy Cut-off (E.C.O.), which shuts off all gas in an event of a overheat condition. The tank shall have _____ magnesium anode rods installed in separate tank head couplings. The heater shall have Non-CFC foam insulation, electronic ignition, and come equipped with an ASME rated T&P relief valve, a cold water inlet Hydrojet® Sediment Reduction System, and an induced draft blower with integral damper for atmospheric venting (115V AC required). It shall be design certified by CSA International for 180°F (82°C) application, either with or without a separate storage tank, and comply with state and local codes and ordinances.

General

All gas water heaters are certified at 300 PSI test pressure (2068 kPa) and 150 PSI working pressure (1034 kPa). All models are design certified by CSA International (formerly AGA/CGA), ANSI standard Z-21.10.3, for up to 180° (82°C) application as an Automatic Storage Heater, and an Automatic Circulating Tank Heater. As an Automatic Storage Heater, all models are complete, self-contained water heating systems. It needs no separate storage tank, pump, wiring or elaborate piping network. When equipped with a mixing valve, it will supply 180°F (82°C) sanitizing and 140°F (60°C) general purpose hot water simultaneously. These models can be used either as a single unit or in multiples connected in series or parallel (recommended).

Dimensions and specifications subject to change without notice in accordance with our policy of continuous product improvement.



Ambler, PA

For U.S. and Canada field service, contact your professional installer or local Bradford White sales representative.

Sales 800-523-2931 • Fax 215-641-1670 / Technical Support 800-334-3393 • Fax 269-795-1089 • Warranty 800-531-2111 • Fax 269-795-1089

International: Telephone 215-641-9400 • Telefax 215-641-9750 / www.bradfordwhite.com

BRADFORD WHITE-CANADA INC. Sales / Technical Support 866-690-0961 / 905-238-0100 • Fax 905-238-0105 / www.bradfordwhite.com

Built to be the Best™

©2011, Bradford White Corporation. All rights reserved.