

# Combi2™

## Residential Atmospheric Vent Combi2™ Energy Saver Gas Water Heater System



Photo is of  
C-DW2-504T10FBN

**The Combi2™ FVIR Defender Safety System® Models Feature:**

- **Bradford White ICON System™**—Intelligent gas control with proven millivolt powered technology and built-in piezo igniter. A standard, off the shelf thermopile converts heat energy from the pilot flame into electrical energy to operate the gas valve and microprocessor. No need for external electricity.
  - **Enhanced Performance**—Proprietary algorithms provide enhanced First Hour Delivery ratings and tighter temperature differentials.
  - **Advanced Temperature Control System**—Microprocessor constantly monitors and controls burner operation to maintain consistent and accurate water temperature levels.
  - **Intelligent Diagnostics**—An exclusive green LED light prompts the installer during start-up and provides ten different diagnostic codes to assist in troubleshooting.
  - **Pilot On Indication**—Flashing green LED provides positive indication that pilot is on.
  - **Separate Immersed Thermowell**—High strength advanced polymer composite thermowell provides isolation between electric temperature sensor and surrounding water. No need to drain the tank when removing gas valve.
- **Internal Double Wall Heat Exchanger**—Double wall 1½" O.D. glass coated (Vitrilas®) steel coil ensures separation of potable water and heating fluid.
  - **3/4" NPT Front Supply and Return Connections.**
  - **Low Heat Exchanger Head Loss**—Up to 8 GPM flow, with less than 6 ft. of head loss. Greatly reduces the required pump size for heat exchange.
- **Advanced ScreenLok® Technology Flame Arrestor Design**—Flame arrestor is designed to prevent ignition of flammable vapor outside of the water heater.
- **Resettable Thermal Switch**—Proven and reliable bimetallic switch prevents burner and pilot operation in case of ongoing flammable vapor burn inside of the combustion chamber or restricted air flow.
- **Maintenance Free**—Regular cleaning of air inlet openings or flame arrestor is not required under normal conditions.
- **Sight Window**—Offers a view into the combustion chamber to observe the operation of the pilot and burner.
- **Factory Installed Hydrojet® Total Performance System**—Cold water inlet sediment reducing device helps prevent sediment build up in tank. Increases first hour delivery of hot water while minimizing temperature build up in tank.
- **Vitrilas® Lining**—Bradford White tanks are lined with an exclusively engineered enamel formula that provides superior protection from the highly corrosive effects of hot water. This formula (Vitrilas®) is fused to the steel surface by firing at a temperature of over 1600°F.
- **Integrated Mixing Device**—Features an accurate, easy to use hand wheel for adjusting mixed water temperature, a pre-piped stainless steel flexible connector for quick installation as well as optional water connections (1/2" NPT recirculation inlet, 1/2" NPT hot water outlet, 1/4" NPT cold water outlet). This required system is easily installed and ensures a comfortable outlet temperature while providing a steady flow of hot water.
- **2" Non-CFC Foam Insulation**—Covers the sides and top of tank, reducing the amount of heat loss. This results in less energy consumption, improved operation efficiencies and jacket rigidity.
- **Pedestal Base.**
- **Water Connections**—3/4" NPT factory installed true dielectric fittings.
- **Two Protective Anode Rods.**
- **T&P Relief Valve**—Installed.
- **Brass Drain Valve**—Tamper proof design.

**FEATURING:**



**10-Year Limited Tank and Heat Exchanger Warranties / 6-Year Limited Warranty on Component Parts.**

For more information on warranty, please visit [www.bradfordwhite.com](http://www.bradfordwhite.com)

For products installed in USA, Canada and Puerto Rico. Some states do not allow limitations on warranties. See complete copy of the warranty included with the heater.

# Residential Atmospheric Vent Gas Water Heater System

## Combi2™ Energy Saver Models

NATURAL GAS AND LIQUID PROPANE GAS

Meet or exceed ASHRAE 90.1b (current standard) C.E.C. Listed  
80% Recovery Efficiency

Model Number	Capacity		LP BTU/Hr. Input	Recovery 90°F Rise*				A Floor to Flue Conn. in.	B Jacket Dia. in.	C Vent Size in.	D Floor to T&P Conn. in.	E Floor to Gas Conn. in.	F Floor to Exchanger Inlet in.	G Floor to Exchanger Outlet in.	H Floor to Top of Heater in.	J Floor to Water Conn. in.	K Depth in.	Approx. Shipping Weight lbs.	
	U.S. Gal.	Imp. Gal.		Nat. BTU/Hr. Input	Nat. U.S. GPH	Nat. Imp. U.S. GPH	LP U.S. GPH												
C-DW2-504T10FBN	45	38	65,000	61,000	70	59	66	55	59½	22	4	50	13	27%	50	56%	60%	24½	238

  

Model Number	Capacity		LP kW Input	Recovery 50°C Rise*				A Floor to Flue Conn. mm.	B Jacket Dia. mm.	C Vent Size mm.	D Floor to T&P Conn. mm.	E Floor to Gas Conn. mm.	F Floor to Exchanger Inlet mm.	G Floor to Exchanger Outlet mm.	H Floor to Top of Heater mm.	J Floor to Water Conn. mm.	K Depth mm.	Approx. Shipping Weight kg.
	Liters	kW Input		Nat. Liters/Hour	LP Liters/Hour	Nat. U.S. GPH	LP U.S. GPH											
C-DW2-504T10FBN	170	19.1	17.9	265	250	1505	559	102	1270	330	780	1270	1432	1534	622	108		

Propane model features a Titanium Stainless Steel propane burner. For Propane (LP) models change "BN" to "SX".

\*Based on manufacturers rated recovery efficiency.

CAEF is .55 and CAAFE% is 80.0.

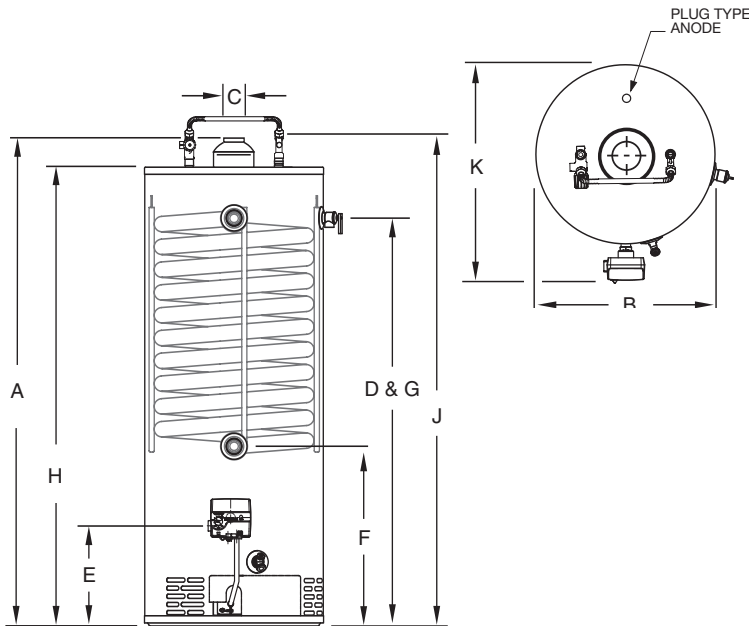

Heat Exchanger Head Loss	
GPM	Ft. of Hd. Loss
2	0.15
5	0.94
8	2.40
10	3.75
12	5.40

### Heat Exchanger Values\*

Supply Temperature	140°F	120°F	100°F
Return Temperature	120°F	100°F	80°F
Differential	20°F	20°F	20°F
Flow Rate	2.3 GPM	3.4 GPM	4.4 GPM
Net Output	20,000 BTU/Hr.	29,000 BTU/Hr.	38,000 BTU/Hr.

\*These values were obtained using 180°F stored tank temperature.

Net Output is the space heating capacity based on normal piping and pickup allowance of 15%.

Actual values may vary based on circulator flow rate, number of zones, water and space heating demands. Numbers subject to change.

### Meets NAECA Requirements

#### General

All gas water heaters are certified at 300 PSI test pressure (2068 kPa) and 150 PSI working pressure (1034 kPa). All potable water and heat exchanger connections are 3/4" NPT (19mm) on 11" (203mm) centers. All gas connections 1/2" (13mm).

All models design certified by CSA International (formerly AGA/CGA), ANSI Z-21.10.1 and peak performance rated.

**Dimensions and specifications subject to change without notice in accordance with our policy of continuous product improvement.**

#### Suitable for Water (Potable) Heating and Space Heating.

Toxic chemicals, such as those used for boiler treatment, shall NEVER be introduced into the potable water side. The potable side of this unit may NEVER be connected to any existing heating system or component(s) previously used with a non-potable water heating appliance. The heat exchanger side of the unit may be used in space heating applications.



Ambler, PA

For U.S. and Canada field service, contact your professional installer or local Bradford White sales representative.

Sales 800-523-2931 • Fax 215-641-1670 / Technical Support 800-334-3393 • Fax 269-795-1089 • Warranty 800-531-2111 • Fax 269-795-1089

International: Telephone 215-641-9400 • Telefax 215-641-9750 / www.bradfordwhite.com

**BRADFORD WHITE-CANADA™ INC.** Sales / Technical Support 866-690-0961 / 905-238-0100 • Fax 905-238-0105 / www.bradfordwhite.com

## Built to be the Best™

©2010, Bradford White Corporation. All rights reserved.