

Light Duty Commercial Ultra Low NOx Energy Saver Gas Water Heater



Photo is of
U-50T-55FR-3N

Identical Dimensions

Same diameter, height and connections as standard units for ease of installation.

The Light Duty FVIR Eco-Defender Safety System[®] Models Feature:

- **Defender Combustion Chamber**—Incorporates the Advanced ScreenLok[®] Technology Flame Arrestor and large split-door design to prevent ignition of flammable vapors outside the water heater.
- **Ultra Low NOx Burner with Primary and Secondary Air Distribution Devices**—Ensures proper air to gas ratio for reduction of NOx generated by the combustion process.
- **Digital Thermal Sensor and Resettable Thermal Switch**—Coordinates with self diagnostic control to prevent water heater operation as needed.
- **Millivolt Powered Control with Built-in Piezo Igniter**—Easy and quick lighting of the pilot burner by push button.
- **Pedestal Base**—Rugged and durable base allows easy transport and positioning, while providing corrosion resistant contact with floor.
- **Maintenance Free**—No regular cleaning of air inlet openings or flame arrestor is required under normal conditions.
- **Sight Window**—Offers a view into the combustion chamber to observe the operation of the pilot and burner.
- **No Electricity Required.**
- **Factory Installed Hydrojet[®] Total Performance System**—Cold water inlet sediment reducing device helps prevent sediment build up in tank. Increases first hour delivery of hot water while minimizing temperature build up in tank.
- **Vitraglas[®] Lining**—Bradford White tanks are lined with a exclusively engineered enamel formula that provides superior protection from the highly corrosive effects of hot water. This formula (Vitraglas[®]) is fused to the steel surface by firing at a temperature of over 1600°F.
- **Self Diagnostic Honeywell Gas Control**—Integrated, immersion gas control learns and monitors the combustion chamber's temperature profile and prevents water heater operation during upset conditions. Also equipped with an LED display to aid in start-up and diagnostics.
- **More Precise Temperature Control**—With an adjustable temperature up to 180°F.
- **Side Connections**—3/4" NPT tapings allow an easy connection for space heating applications.
- **2" Non-CFC Foam Insulation**—Surrounds the tank surface, saving energy by retarding loss of heat.
- **Water Connections**—3/4" NPT factory installed true dielectric fittings extend water heater life and eases installation.
- **Factory Installed Heat Traps**—Design incorporates a flexible disk that reduces heat loss in piping and eliminates the potential for noise generation.
- **Protective Magnesium Anode Rod**—Provides added protection against corrosion for long trouble-free service.
- **"Snap Lock" Draft Diverter.**
- **T&P Relief Valve**—Installed.
- **Brass Drain Valve**—Tamper proof.
- **Meets SCAQMD Rule 1121 (10ng/J NOx limit).**
- **Design Certified by CSA International (formerly AGA and CGA).**

3 or 5-Year Limited Tank Warranties / 1-Year Limited Warranty on Component Parts.

For more information on warranty, please visit www.bradfordwhite.com

For products installed in USA, Canada and Puerto Rico. Some states do not allow limitations on warranties. See complete copy of the warranty included with the heater.



Commercial Atmospheric Vent Gas Water Heater



Light Duty Ultra Low NOx Energy Saver Models

NATURAL GAS

Meet or exceed ASHRAE 90.1b (current standard) C.E.C. Listed
Recovery efficiency ranging up to 80%

Model Number	Capacity		Recovery at 100°F Rise*	A Floor to Flue Conn.	B Jacket Dia.	C Vent Size	D Floor to T&P Conn.	E Floor to Gas Conn.	F Floor to Space Heating Return in.	G Floor to Space Heating Outlet in.	H Floor to Water Conn.	K Depth	Approx. Shipping Weight		
	U.S. Gal.	Imp. Gal.												Nat. BTU/Hr. Input	Nat. U.S. GPH
U-50T-55FR-3N	48	40	55,000	53	44	59 1/4	22	4	50	11 1/8	13 1/2	50	57	26	174
U-65T-55FR-3N	65	54	55,000	53	44	63	24	4	53 1/2	11 1/8	13 1/2	53 1/2	60 3/4	28	213

Model Number	Capacity		Recovery at 38°C Rise*	A Floor to Flue Conn.	B Jacket Dia.	C Vent Size	D Floor to T&P Conn.	E Floor to Gas Conn.	F Floor to Space Heating Return mm.	G Floor to Space Heating Outlet mm.	H Floor to Water Conn.	K Depth	Approx. Shipping Weight
	Liters	Nat. kW Input											
U-50T-55FR-3N	182	16.1	200	1505	559	102	1270	330	343	1270	1448	660	74
U-65T-55FR-3N	246	16.1	200	1600	609	102	1359	309	342	1359	1543	711	93

Available in Natural Gas only.

For 5 year models, change suffix from "3" to "5".

*Based on manufacturers rated recovery efficiency.

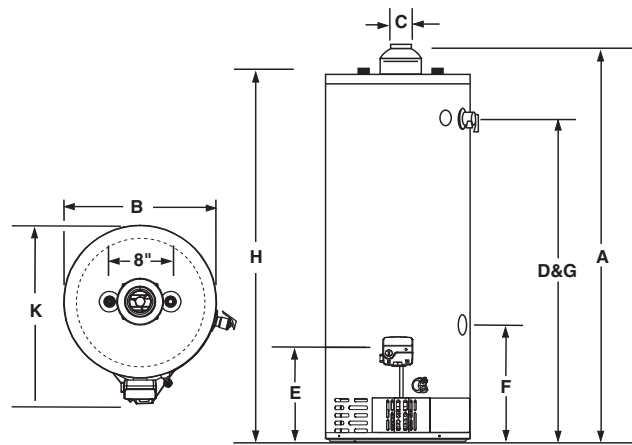

All models meet SCAQMD rule 1121 requirement of 10ng/J, or less, NOx emissions.

Meets NAECA Requirements

General

All gas water heaters are certified at 300 PSI test pressure (2068 kPa) and 150 PSI working pressure (1034 kPa). All water connections are 3/4" NPT (19mm) on 8" (203mm) centers. All Gas Connections are 1/2" (13mm).

All models design certified by CSA International (formerly AGA/CGA), to meet ANSI standard Z-21.10.1 and peak performance rated.

Dimensions and specifications subject to change without notice in accordance with our policy of continuous product improvement.

Suitable for Water (Potable) Heating and Space Heating.

Toxic chemicals, such as those used for boiler treatment, shall NEVER be introduced into this system. This unit may NEVER be connected to any existing heating system or component(s) previously used with a non-potable water heating appliance.



For U.S. and Canada field service, contact your professional installer or local Bradford White sales representative.

Sales 800-523-2931 • Fax 215-641-1670 / Technical Support 800-334-3393 • Fax 269-795-1089 • Warranty 800-531-2111 • Fax 269-795-1089

International: Telephone 215-641-9400 • Telefax 215-641-9750 / www.bradfordwhite.com

BRADFORD WHITE-CANADA INC. Sales / Technical Support 866-690-0961 / 905-238-0100 • Fax 905-238-0105 / www.bradfordwhite.com

Built to be the Best™

©2009, Bradford White Corporation. All rights reserved.