

Commercial Flue Damper Electronic Ignition Energy Saver Gas Water Heater



Photo is of
D-75T-125-3N

The Commercial Flue Damper Models feature:

- **Honeywell Integrated Control**—Intelligent proven design combines temperature control, diagnostic codes, and system ignition functions into a single control board with a digital LCD display. Control panel cover tilts down for ease of wiring and service.
- **Operation Mode**—Two different digitally displayed operation modes have the capability of adjusting the temperature setting up to 180°F (82°C), and adjusting the degree setting (°F to °C, or °C to °F).
- **Service Mode**—Eight different digitally displayed service modes can be easily cycled through by pressing the select button. There is the capability of adjusting the temperature setting up to 180°F (82°C), adjusting the degree setting (°F to °C, or °C to °F), locking the maximum temperature setting that can be adjusted in operation mode, displaying the average water temperature (if water heater has two sensors), displaying the upper temperature sensor, displaying the lower temperature sensor, displaying the flame current of the pilot flame, and displaying diagnostic codes.
- **Electronic Ignition**—High voltage, low current electricity is sent to the pilot electrode initiating a spark to ignite the pilot gas. This results in savings of pilot gas during stand-by periods because the pilot flame only operates when there's a call for heat.
- **Automatic Flue Damper**—Reduces stand-by loss, saving gas consumption and improving overall efficiency.
- **Factory Installed Hydrojet[®] Sediment Reduction System**—Cold water inlet sediment reducing device helps prevent sediment build up in tank. Increases first hour delivery of hot water while minimizing temperature build up in tank.
- **Vitraglas[®] Lining**—Bradford White tanks are lined with an exclusively engineered enamel formula that provides superior tank protection from the highly corrosive effects of hot water. This formula (Vitraglas[®]) is fused to the steel surface by firing at a temperature of over 1600°F (871°C).
- **Non-CFC Foam Insulation**—Covers the sides and top of tank, reducing the amount of heat loss. This results in less energy consumption, improved operation efficiencies and jacket rigidity.
- **Water Connections**—Factory installed true dielectric waterway fittings extend water heater life and eases installation. Multiple water connection locations allow for greater installation flexibility.
- **Hand Hole Cleanout**—Allows inspection of tank interior and facilitates the removal of sediment deposits.
- **E.C.O.**—An automatic re-set Energy Cut Off (E.C.O) shuts off all gas in event of an overheat condition. This automatically re-sets when operation conditions are back to normal.
- **Magnesium Anode Rods**—Provide added protection against corrosion for long trouble-free service.
- **Sanitizing Capability**—Temperature setting up to 180°F (82°C).
- **ASME Code Available on all Models Above 200,000 BTU/Hr.**
- **NSF Construction Available.**
- **Low NOx Construction Available.**
- **North Carolina Code Compliant.**
- **T&P Relief Valve**—Installed.
- **Brass Drain Valve**—Tamper proof.
- **Design certified by CSA International.**



3-Year Limited Tank Warranties / 1-Year Limited Warranty on Component Parts.

For more information on warranty, please visit www.bradfordwhite.com

For products installed in USA, Canada and Puerto Rico. Some states do not allow limitations on warranties. See complete copy of the warranty included with the heater.

Commercial Gas Water Heater

Electronic Ignition Energy Saver Models

NATURAL GAS AND LIQUID PROPANE GAS

Meet or exceed ASHRAE 90.1b (current standard) C.E.C. Listed

Model Number	Capacity		Nat. BTU/Hr. Input	LP BTU/Hr. Input	1st Hour Delivery Rating at 100°F Rise	GPH Recovery at Degree Rise*			A Top Vent Height in.	B Jacket Dia. in.	C Vent Dia. in.	D Front Hot Water Conn. in.	E Floor to Gas Conn. in.	F Front Cold Water Conn. in.	H Floor to Top of Heater in.	J Floor to Top Water Conn. in.	Water Conn. in.	Gas Conn. Dia.	Relief Valve Open. in.	Approx. Shipping Weight (lbs.)	
	U.S. Gal.	Imp. Gal.				40°F	100°F	140°F												Std.	ASME
D-38T-155-3N+	38	31	155,000	155,000	177	376	150	107	51	28 1/4	6	35	4 5/8	19 5/8	43 1/2	-	1 1/2	3/4	3/4	438	-
D-75T-125-3N	75	62	125,000	125,000	174	303	121	86	72 1/4	28 1/4	5	54 1/2	4 3/4	34	65	67 1/8	1 1/2	3/4	3/4	520	-
D-75T-160-3N	75	62	160,000	155,000	208	389	155	111	72 1/4	28 1/4	6	54 1/2	4 3/4	34	65	67 1/8	1 1/2	3/4	3/4	520	-
D-80T-180-3N	80	67	180,000	180,000	231	436	175	124	71 7/8	28 1/4	6	56	4 3/4	19 1/2	64 1/2	66 1/4	1 1/2	3/4	3/4	540	-
D-80T-199-3N	80	67	199,999	199,999	250	485	194	139	71 7/8	28 1/4	6	56	4 3/4	19 1/2	64 1/2	66 1/4	1 1/2	3/4	3/4	540	-
D-80T-250-3N(A)	80	67	250,000	235,000	298	606	242	173	71 7/8	28 1/4	6	56	4 3/4	19 1/2	64 1/2	66 1/4	1 1/2	3/4	1	540	590
D-100T-199-3N	98	82	199,999	199,999	263	485	194	139	83 3/8	28 1/4	6	67	4 3/4	19 1/2	75 1/2	77 1/4	1 1/2	3/4	3/4	610	-
D-100T-250-3N(A)	98	82	250,000	235,000	311	606	242	173	83 3/8	28 1/4	6	67	4 3/4	19 1/2	75 1/2	77 1/4	1 1/2	3/4	1	610	690
D-75T-300-3N(A)	75	62	300,000	300,000	344	727	291	208	74 3/4	28 1/4	7	54 1/8	10 1/2	29	65 3/4	-	1 1/2	3/4	1	590	645
D-65T-370-3N(A)	65	54	370,000	370,000	405	897	359	256	73 1/4	28 1/4	8	54 1/8	10 1/2	29	64 3/4	-	1 1/2	3/4	1(N)	665	720
D-65T-399-3N(A)**	65	54	399,999	399,999	424	970	388	277	73 1/4	28 1/4	8	54 1/8	10 1/2	29	64 3/4	-	1 1/2	1(N)	1	665	720
D-80T-425-3N(A)	80	67	425,000	425,000	468	1030	412	294	82 3/4	28 1/4	10	64 1/2	10 1/2	29	75 1/2	-	1 1/2	1(N)	1	750	800
D-80T-505-3N(A)	80	67	505,000	505,000	527	1178	471	337	82 3/4	28 1/4	10	64 1/2	10 1/2	29	75 1/2	-	1 1/2	1(N)	1	750	800
D-100S-199-3N	100	83	199,999	199,999	264	485	194	139	76 3/4	28 1/4	6	60 3/8	4 5/8	20 3/4	67 7/8	70	1 1/2 (T&F)	3/4	3/4	667	-
D-100S-250-3N(A)	100	83	250,000	250,000	312	606	242	173	76 3/4	28 1/4	6	60 3/8	4 5/8	20 3/4	67 7/8	70	1 1/2 (T&F)	3/4	1	667	702
D-100L-199-3N	100	83	199,999	199,999	264	485	194	139	75	30 1/4	6	56 1/2	4 1/2	23 1/2	64 3/4	67	1 1/2 (T&F)	3/4	3/4	725	-
D-100L-250-3N(A)	100	83	250,000	250,000	312	606	242	173	75	30 1/4	6	56 1/2	4 1/2	23 1/2	64 3/4	67	1 1/2 (T&F)	3/4	1	725	765
D-100L-270-3N(A)**	100	83	270,000	270,000	332	655	262	187	75	30 1/4	6	56 1/2	4 1/2	23 1/2	64 3/4	67	1 1/2 (T&F)	3/4	1	725	765
D-100L-300-3N(A)	100	83	300,000	300,000	361	727	291	208	75 3/8	30 1/4	7	56 1/2	4 1/2	23 1/2	64 3/4	67	1 1/2 (T&F)	3/4	1	725	765
D-80L-399-3N(A)	80	67	399,999	375,000	444	970	388	277	71 1/2	30 1/4	8	51 1/2	10 1/2	23 1/2	60 1/4	-	1 1/2 (F)	1(N)	1	800	835
D-80L-450-3N(A)	80	67	450,000	425,000	492	1091	436	312	69	30 1/4	10	51 1/2	10 1/2	23 1/2	60 1/4	-	1 1/2 (F)	1(N)	1	800	835
D-80L-505-3N(A)	80	67	505,000	475,000	545	1224	489	350	69	30 1/4	10	51 1/2	10 1/2	23 1/2	60 1/4	-	1 1/2 (F)	1(N)	1	800	835

Model Number	Capacity		Nat. kW/Hr. Input	LP kW/Hr. Input	1st Hour Delivery Rating at 56°C Rise	LPH Recovery at Degree Rise*			A Top Vent Height mm.	B Jacket Dia. mm.	C Vent Dia. mm.	D Front Hot Water Conn. mm.	E Floor to Gas Conn. mm.	F Front Cold Water Conn. mm.	H Floor to Top of Heater mm.	J Floor to Top Water Conn. mm.	Water Conn. mm.	Gas Conn. Dia.	Relief Valve Open. mm.	Approx. Shipping Weight (kg.)	
	Liters					22°C	56°C	78°C												Std.	ASME
D-38T-155-3N+	144	45.4	45.4	670	1391	556	397	1295	718	152	889	117	492	1105	-	38	19	19	199	-	
D-75T-125-3N	284	36.6	36.6	659	1147	458	326	1835	718	127	1384	121	864	1651	1705	38	19	19	236	-	
D-75T-160-3N	284	46.8	45.4	787	1431	572	409	1835	718	152	1384	121	864	1651	1705	38	19	19	236	-	
D-80T-180-3N	303	52.7	52.7	874	1650	662	469	1826	718	152	1422	121	495	1638	1683	38	19	19	245	-	
D-80T-199-3N	303	58.6	58.6	946	1836	734	526	1826	718	152	1422	121	495	1638	1683	38	19	19	245	-	
D-80T-250-3N(A)	303	73.2	68.9	1128	2294	916	655	1826	718	152	1422	121	495	1638	1683	38	19	25	245	268	
D-100T-199-3N	371	58.6	58.6	995	1836	734	526	2118	718	152	1702	121	495	1918	1962	38	19	19	277	-	
D-100T-250-3N(A)	371	73.2	68.9	1177	2294	916	655	2118	718	152	1702	121	495	1918	1962	38	19	25	277	313	
D-75T-300-3N(A)	284	87.9	87.9	1302	2752	1101	787	1889	718	178	1375	267	737	1670	-	38	19	25	268	393	
D-65T-370-3N(A)	246	108.4	108.4	1533	3395	1359	969	1861	718	203	1375	267	737	1645	-	38	25(N)	25	302	327	
D-65T-399-3N(A)**	246	117.2	117.2	1605	3671	1469	1048	1861	718	203	1375	267	737	1645	-	38	25	25	302	327	
D-80T-425-3N(A)	303	124.5	124.5	1771	3899	1559	1113	2102	718	254	1638	267	737	1918	-	38	25(N)	25	340	363	
D-80T-505-3N(A)	303	148.0	148.0	1995	4459	1783	1276	2102	718	254	1638	267	737	1918	-	38	25(N)	25	340	363	
D-100S-199-3N	303	58.6	58.6	999	1836	734	526	1949	718	152	1534	114	527	1724	1778	38 (T&F)	19	19	302	-	
D-100S-250-3N(A)	303	73.2	73.2	1181	2294	916	655	1949	718	152	1534	114	527	1724	1778	38 (T&F)	19	25	302	318	
D-100L-199-3N	303	58.6	58.6	999	1836	734	526	1905	768	152	1435	114	597	1645	1702	38 (T&F)	19	19	329	-	
D-100L-250-3N(A)	379	73.2	73.2	1181	2294	916	655	1905	768	152	1435	114	597	1645	1702	38 (F)	19	25	329	347	
D-100L-270-3N(A)**	379	79.0	79.0	1257	2479	992	708	1915	768	152	1435	114	597	1645	1702	38 (F)	19	25	329	347	
D-100L-300-3N(A)	379	87.9	87.9	1366	2752	1101	787	1905	768	178	1435	114	597	1645	1702	38 (F)	19	25	329	347	
D-80L-399-3N(A)	379	117.2	109.9	1681	3671	1469	1048	1816	768	203	1308	267	597	1530	-	38 (F)	25(N)	25	363	379	
D-80L-450-3N(A)	379	131.8	124.6	1862	4129	1650	1181	1753	768	254	1308	267	597	1530	-	38 (F)	25(N)	25	363	379	
D-80L-505-3N(A)	379	148.0	139.2	2063	4633	1851	1325	1753	768	254	1308	267	597	1530	-	38 (F)	25(N)	25	363	379	

(A) = ASME Code Available
 (F) = Front Water Connection
 (T) = Top Water Connection
 ** = Available in Natural Gas Only
 + = Fiberglass Insulation
 For Propane (LP) Gas models change suffix "N" to "X".
 220V/50Hz Available - Consult factory.

* Recoveries and First Hour Delivery Rating are based on Natural Gas Input and 80% Thermal Efficiency. Low NOx models are not available for inputs over 399,999 BTU/Hr.
For Low NOx compliance to meet SCAQMD requirements place an "E" following the BTU input identifier of the model number.
 Example: D-75T-125E-3N
 Amperage Draw = .5 for damper models/less than 4 for induced draft models.
Power Vent Kits - available for inputs from 125,000 to 505,000 BTU/Hr.
 For 5 year models change suffix from "3" to "5".

Commercial Gas Water Heater

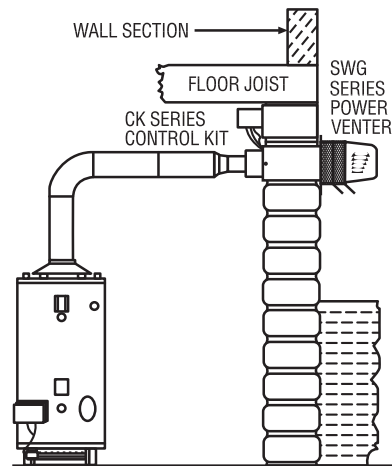
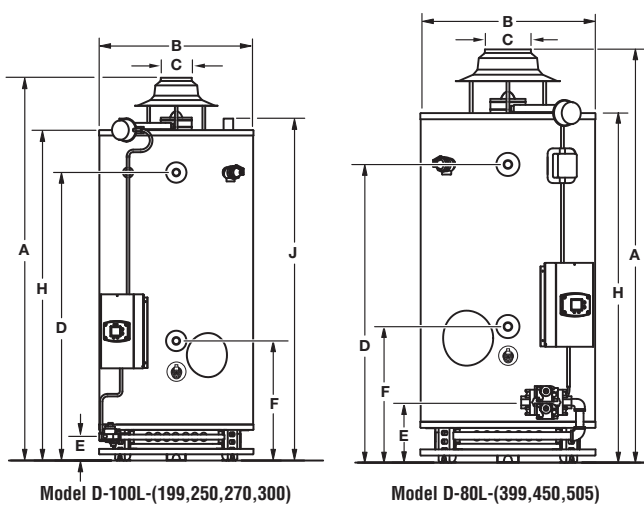
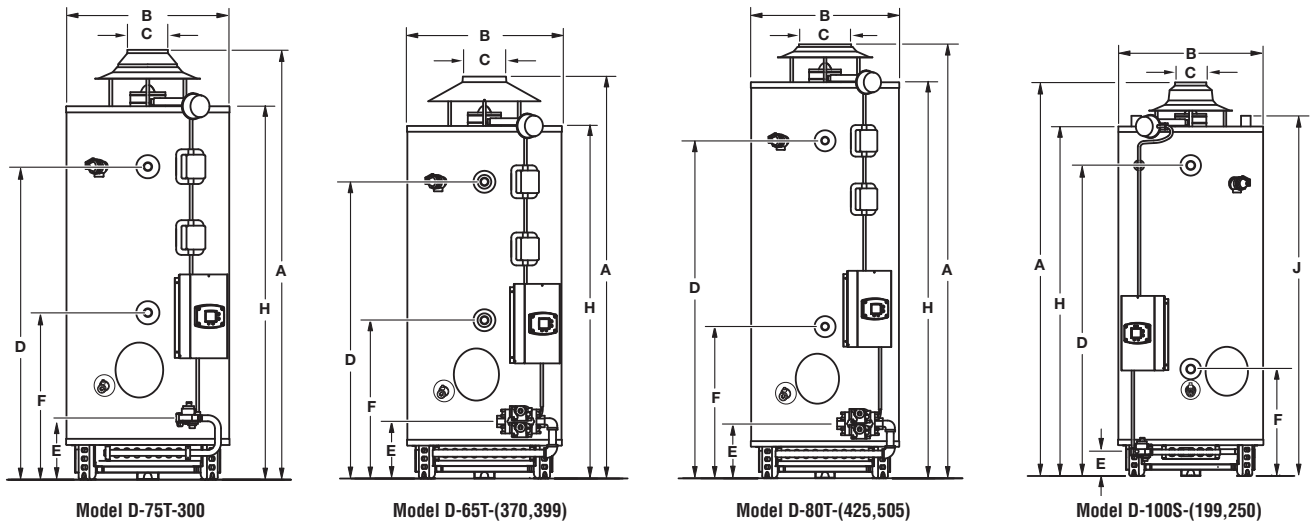
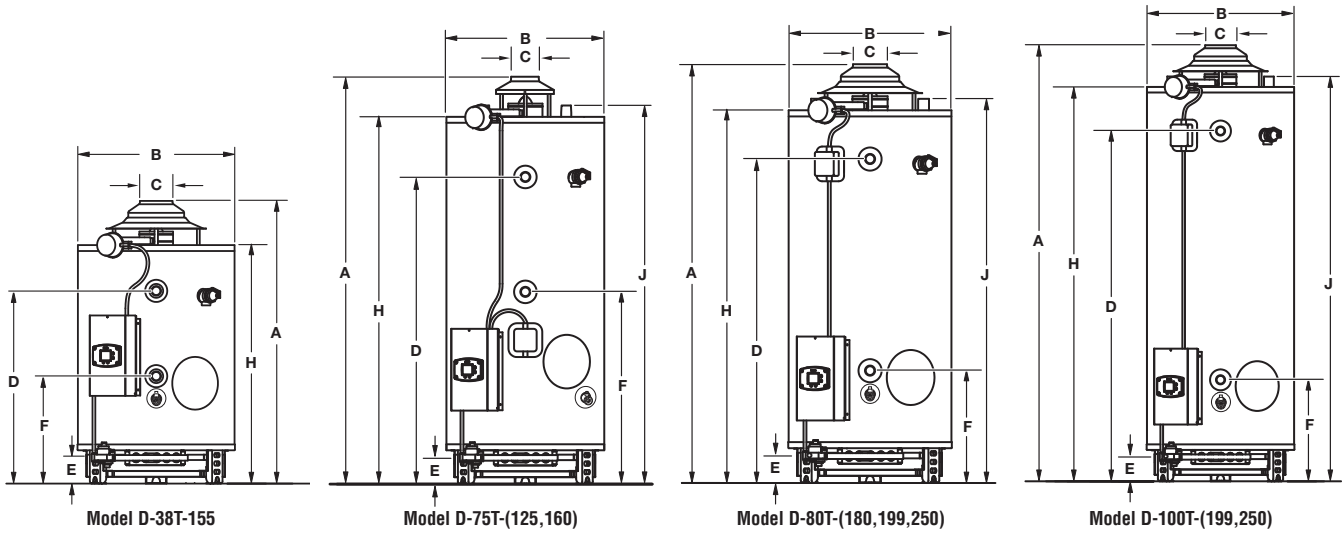

TYPICAL APPLICATIONS

Optional Power Vent Kits – available for inputs from 125,000 to 505,000 BTU/Hr.

BTU Input Range	Kit Number
125,000 to 290,000 BTU/Hr.:	239-81764-00
300,000 to 399,999 BTU/Hr.:	239-81766-00
425,000 to 505,000 BTU/Hr.:	239-82148-00

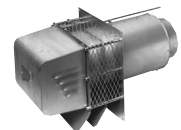

Commercial Gas Water Heater

Sample Specification

The water heater shall be a Bradford White model with a rated storage capacity of not less than _____ gallons (_____ liters), a minimum gas input of _____ BTU/Hr. (_____ kW), a minimum recovery of _____ GPH (_____ LPH), and a minimum First Hour Delivery of _____ Gal. (_____ liters). The tank shall be Vitraglas® lined and have a bolted hand hole cleanout. A digital LCD display shall be integrated into the front control box, and the control shall be an adjustable electronic thermostat to any temperature up to 185°F (85°C) must have an automatic re-set Energy Cut-off (E.C.O), which shuts off all gas in an event of a overheat condition. The tank shall have _____ magnesium anode rods installed in separate tank head couplings. The heater shall have Non-CFC foam insulation, electronic ignition, and come equipped with an ASME rated T&P relief valve, a cold water inlet Hydrojet® Sediment Reduction System, and a automatic flue damper (115V AC required). It shall be design certified by CSA International for 180°F (82°C) application, either with or without a separate storage tank, and comply with state and local codes and ordinances.

General

All gas water heaters are certified at 300 PSI test pressure (2068 kPa) and 150 PSI working pressure (1034 kPa). All models are design certified by CSA International (formerly AGA/CGA), ANSI standard Z-21.10.3, for up to 180°F (82°C) application as an Automatic Storage Heater, and an Automatic Circulating Tank Heater. As an Automatic Storage Heater, all models are complete, self-contained water heating systems. It needs no separate storage tank, pump, wiring or elaborate piping network. When equipped with a mixing valve, it will supply 180°F (82°C) sanitizing and 140°F (60°C) general purpose hot water simultaneously. These models can be used either as a single unit or in multiples connected in series or parallel (recommended).

Dimensions and specifications subject to change without notice in accordance with our policy of continuous product improvement.



Ambler, PA

For U.S. and Canada field service, contact your professional installer or local Bradford White sales representative.

Sales 800-523-2931 • Fax 215-641-1670 / Technical Support 800-334-3393 • Fax 269-795-1089 • Warranty 800-531-2111 • Fax 269-795-1089

International: Telephone 215-641-9400 • Telefax 215-641-9750 / www.bradfordwhite.com

BRADFORD WHITE-CANADA® INC. Sales / Technical Support 866-690-0961 / 905-238-0100 • Fax 905-238-0105 / www.bradfordwhite.com

Built to be the Best™

©2012, Bradford White Corporation. All rights reserved.