

Commercial Power Direct Vent Co-Axial Vent Energy Saver Gas Water Heater



Photo is of
PDV-100T-360-3N

The Power Direct Vent Co-Axial Vent Models feature:

- **Honeywell Integrated Control**—Intelligent proven design combines temperature control, diagnostic codes, and system ignition function into a single control board with a digital LCD display. Control panel cover tilts down for ease of wiring and service.
- **Operation Mode**—Two different digitally displayed operation modes have the capability of adjusting the temperature setting up to 180°F (82°C), and adjusting the degree setting (°F to °C, or °C to °F).
- **Service Mode**—Eight different digitally displayed service modes can be easily cycled through by pressing the select button. There is the capability of adjusting the temperature setting up to 180°F (82°C), adjusting the degree setting (°F to °C, or °C to °F), locking the maximum temperature setting that can be adjusted in operation mode, displaying the average water temperature (if water heater has two sensors), displaying the upper temperature sensor, displaying the lower temperature sensor, displaying the flame current of the pilot flame, and displaying diagnostic codes.
- **Electronic Ignition**—High voltage, low current electricity is sent to the pilot electrode initiating a spark to ignite the pilot gas. This results in savings of pilot gas during stand-by periods because the pilot flame only operates when there's a call for heat.
- **Automatic Blower Motor**—Induced draft for direct venting.
- **Factory Installed Hydrojet[®] Sediment Reduction System**—Cold water inlet sediment reducing device helps prevent sediment build up in tank. Increases first hour delivery of hot water while minimizing temperature build up in tank.
- **Co-axial Vent**—A pipe inside a pipe. This allows combustible air to enter from the outside through an outer pipe and exhausts the products of combustion through an inner pipe. Ideal for installations with a negative air pressure situation.
- **Vitraglas[®] Lining**—Bradford White tanks are lined with a exclusively engineered enamel formula that provides superior protection from the highly corrosive effects of hot water. This formula (Vitraglas[®]) is fused to the steel surface by firing at a temperature of over 1600°F (871°C).
- **E.C.O.**—An automatic re-set Energy Cut Off (E.C.O) shuts off all gas in event of an overheat condition. This automatically re-sets when operation conditions are back to normal.
- **Non-CFC Foam Insulation**—Covers the sides and top of tank, reducing the amount of heat loss. This results in less energy consumption, improved operation efficiencies and jacket rigidity.
- **Multiple Water Connections**—1½" top and front, 2" rear NPT factory installed dielectric fittings extend water heater life and eases installation.
- **Protective Magnesium Anode Rods**—Provide added protection against corrosion for long trouble-free service.
- **Hand Hole Cleanout**—Allows inspection of tank interior and removal of sediment deposits.
- **Sanitizing Capability**—Temperature setting up to 180°F (82°C).
- **NSF Construction Available.**
- **Low NOx Construction Available.**
- **ASME Code Available.**
- **T&P Relief Valve**—Installed.
- **Brass Drain Valve**—Tamper proof.
- **Design Certified by CSA International (Formerly AGA and CGA).**

3-Year Limited Tank Warranties / 1-Year Limited Warranty on Component Parts.

For more information on warranty, please visit www.bradfordwhite.com

For products installed in USA, Canada and Puerto Rico. Some states do not allow limitations on warranties. See complete copy of the warranty included with the heater.



Power Direct Vent Series Water Heater

Power Direct Vent Energy Saver Models

NATURAL GAS AND LIQUID PROPANE GAS

Meet or exceed ASHRAE 90.1b (current standard) C.E.C. Listed
80% Recovery Efficiency

Model Number	Capacity		Nat. & LP BTU/Hr. Input	First Hr. Del. Rating @100°F Rise	Recovery at Degree °F Rise*			A Floor to Vent Conn.	B Jacket Dia.	C Floor to Gas Conn.	D Floor to Hot Water Conn. in.	E Floor to Cold Water Conn. in.	F Floor to Heater Top in.	G Floor to Top Water Conn. in.	Gas Conn. in.	Relief Valve Open in.	K Depth in.	Approx. Shipping Weight lbs.	
	U.S. Gal.	Imp. Gal.			40°F	100°F	140°F											Std.	ASME
PDV-80T-300-3N(A)	80	66	300,000	347	728	291	208	69 ⁵ / ₈	28 ¹ / ₄	13 ⁵ / ₈	51 ³ / ₈	20 ⁷ / ₈	63 ³ / ₄	65 ³ / ₄	3/4	1	44 ⁵ / ₈	665	740
PDV-100T-360-3N(A)	100	83	360,000	419	873	349	249	78 ⁵ / ₈	28 ¹ / ₄	13 ⁵ / ₈	60 ³ / ₈	20 ⁷ / ₈	72 ³ / ₄	74 ³ / ₄	3/4	1	44 ⁵ / ₈	735	815

Model Number	Capacity		Nat. & LP kW Input	First Hr. Del. Rating @56°C Rise	Recovery at LPH °C Rise*			A Floor to Vent Conn.	B Jacket Dia.	C Floor to Gas Conn.	D Floor to Hot Water Conn. mm.	E Floor to Cold Water Conn. mm.	F Floor to Heater Top mm.	G Floor to Top Water Conn. mm.	Gas Conn. mm.	Relief Valve Open mm.	K Depth mm.	Approx. Shipping Weight kg.	
	Liters	Gal.			4.4°C	56°C	60°C											Std.	ASME
PDV-80T-300-3N(A)	303	87.9	1313	2755	1101	787	1765	718	356	1308	527	1622	1670	19	25	1143	302	336	
PDV-100T-360-3N(A)	379	105.5	1586	3304	1321	942	1892	718	356	1537	527	1851	1899	19	25	1143	333	370	

*Recoveries and First Hour Delivery Ratings are based on Natural Gas input and 80% Thermal Efficiency.

For Propane (LP) models change suffix "N" to "X".

(A) = ASME Code Available

For 5 year models change suffix from "3" to "5".

220V/50Hz Available - Consult factory.

For LowNOx compliance to meet SCAQMD requirements, place an "E" following the BTU Input identifier of the model number. Example: PDV-80T-300E-3N(A)

**Note: The standard vent kit (p/n 243-41769-01) shipped with the heater, but in a separate carton includes: horizontal vent terminal, an elbow, condensate tee, vent connector clamps, and two 39" (990mm) straight sections of co-axial vent pipe. Can be cut for installation. Optional vent kits are available and will allow for extensions up to 21 feet. For further details please reference the installation instructions.

For vertical venting please consult factory for optional vent components.

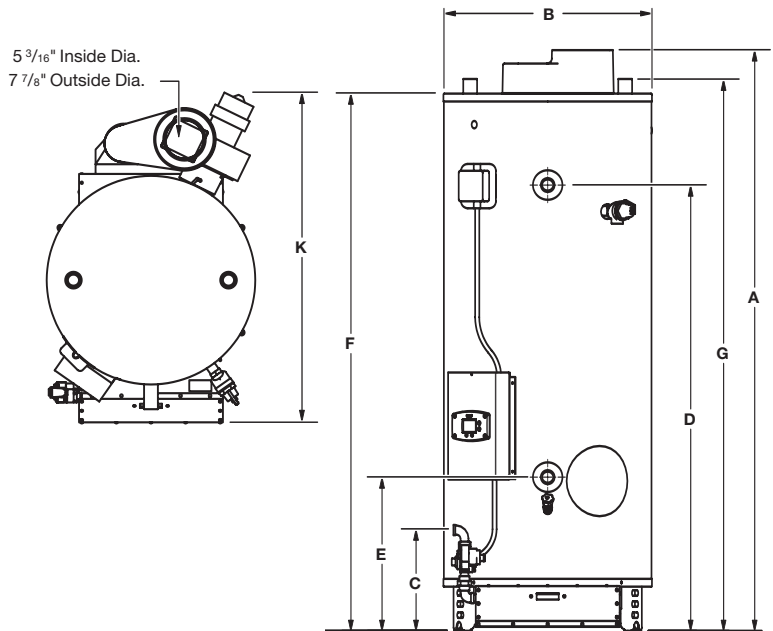

Sample Specification

The water heater shall be a Bradford White model with a rated storage capacity of not less than _____ gallons (_____ liters), a minimum gas input of _____ BTU/Hr. (_____ kW), a minimum recovery of _____ GPH (_____ LPH), and a minimum First Hour Delivery of _____ Gal. (_____ liters). The tank shall be Vitraglas® lined and have a bolted hand hole cleanout. A digital LCD display shall be integrated into the front control box, and the control shall be an adjustable electronic thermostat to any temperature up to 185°F (85°C), and must have an automatic re-set Energy Cut-off (E.C.O.), which shuts off all gas in an event of an overheat condition. The tank shall have _____ magnesium anode rods installed in separate tank head couplings. The heater shall have Non-CFC foam insulation, electronic ignition, and come equipped with an ASME rated T&P relief valve, a cold water inlet Hydrojet® Sediment Reduction System, and an induced draft blower motor for direct venting (115V AC required). It shall be design certified by CSA International for 180°F (82°C) application, either with or without a separate storage tank, and comply with state and local codes and ordinances.

General

All gas water heaters are certified at 300 PSI test pressure (2068 kPa) and 150 PSI working pressure (1034 kPa). All models are design certified by CSA International (formerly AGA/CGA), ANSI standard Z-21.10.3, for up to 180°F (82°C) application as an Automatic Storage Heater, and an Automatic Circulating Tank Heater. As an Automatic Storage Heater, all models are complete, self-contained water heating systems. It needs no separate storage tank, pump, wiring or elaborate piping network. When equipped with a mixing valve, it will supply 180°F (82°C) sanitizing and 140°F (60°C) general purpose hot water simultaneously. These models can be used either as a single unit or in multiples connected in series or parallel (recommended).

Dimensions and specifications subject to change without notice in accordance with our policy of continuous product improvement.



Ambler, PA

For U.S. and Canada field service, contact your professional installer or local Bradford White sales representative.

Sales 800-523-2931 • Fax 215-641-1670 / Technical Support 800-334-3393 • Fax 269-795-1089 • Warranty 800-531-2111 • Fax 269-795-1089

International: Telephone 215-641-9400 • Telefax 215-641-9750 / www.bradfordwhite.com

BRADFORD WHITE-CANADA INC. Sales / Technical Support 866-690-0961 / 905-238-0100 • Fax 905-238-0105 / www.bradfordwhite.com

Built to be the Best™

©2009, Bradford White Corporation. All rights reserved.