

TTW²

Residential Ultra Low NOx Power Vent Energy Saver Gas Water Heater



Photo is of
U-2-TW-50T6FRN

Identical Dimensions

Same diameter, height and connections as standard units for ease of installation.

FEATURING:



The TTW² FVIR Eco-Defender Safety System® Models Feature (50 and 65 gallon models only):

- **Defender Combustion Chamber**—Incorporates the Advanced ScreenLok® Technology Flame Arrestor and large split-door design to prevent ignition of flammable vapors outside the water heater.
- **Flammable Vapor Sensor and Resettable Thermal Switch**—Coordinates with control to prevent burner operation if flammable vapors are detected. The sensor will also prevent operation if there is ongoing flammable vapor burn inside the combustion chamber.
- **Maintenance Free**—No regular cleaning of air inlet openings or flame arrestor is required under normal conditions.
- **Sight Window**—Offers a view into the combustion chamber to observe the operation of the pilot and burner.

All TTW² Models Feature:

- **Ultra Low NOx Burner with Primary and Secondary Air Distribution Devices**—Ensures proper air to gas ratio for reduction of NOx generated by the combustion process.
- **Bradford White ICON System™**—Intelligent gas control with spark to pilot ignition system eliminates the constant burning pilot. This results in savings of pilot gas during stand by periods (120 V.A.C.).
 - **Enhanced Performance**—Proprietary algorithms provide enhanced First Hour Delivery ratings and tighter temperature differentials.
 - **Advanced Temperature Control System**—Microprocessor constantly monitors and controls burner operation to maintain consistent and accurate water temperature levels.
 - **Intelligent Diagnostics**—An exclusive green LED light prompts the installer during start-up and provides ten different diagnostic codes to assist in troubleshooting.
 - **Separate Immersed Thermowell**—High strength advanced polymer composite thermowell provides isolation between electric temperature sensor and surrounding water. No need to drain the tank when removing gas valve.
- **Compatible With Optional Accessory Packages**—Performance Package, Protection Package and Inlet Shut-off Valve.
- **Powerful Blower Motor**—Our significantly quiet design has greater resistance to outside winds and the power to vent in many difficult venting situations.
- **Horizontal and Vertical Venting**—With 3" or 4" PVC, ABS or CPVC (Maximum equivalent vent length on reverse side).
- **Factory Installed Hydrojet® 2™ Total Performance System**—Cold water inlet sediment reducing device helps prevent sediment build up in tank. Increases first hour delivery of hot water while minimizing temperature build up at top of tank.
- **Vitraglas® Lining**—Bradford White tanks are lined with an exclusively engineered enamel formula that provides superior tank protection from the highly corrosive effects of hot water. This formula (Vitraglas®) is fused to the steel surface by firing at a temperature of over 1600°F (871°C).
- **2" Non-CFC Foam Insulation**—Covers the sides and top of tank, reducing the amount of heat loss. This results in less energy consumption, improved operation efficiencies and jacket rigidity.
- **Water Connections**—3/4" NPT factory installed true dielectric fittings.
- **Factory Installed Heat Traps**—Design incorporates a flexible disk that reduces heat loss in piping and eliminates the potential for noise generation.
- **Protective Magnesium Anode Rod.**
- **3/4" NPT Side Connections.**
- **Pedestal Base.**
- **T&P Relief Valve**—Included.
- **Low Restriction Brass Drain Valve**—Durable tamper proof design.
- **Complies with the latest ultra-low NOx requirement (10 ng/J NOx limit).**

6 or 10-Year Limited Tank Warranties / 6 or 10-Year Limited Warranty on Component Parts.

For more information on warranty, please visit www.bradfordwhite.com

For products installed in USA, Canada and Puerto Rico. Some states do not allow limitations on warranties. See complete copy of the warranty included with the heater.

Residential Power Vent Gas Water Heater

TTW® 2 Ultra Low NOx Energy Saver Models

Meet or exceed ASHRAE 90.1b (current standard) C.E.C. Listed
80% Recovery Efficiency

NATURAL GAS

Model Number	Capacity		Recovery 90°F Rise*	A Floor to Vent Conn.		B Jacket Dia.	C Vent Size	D Floor to T&P Conn.	E Floor to Gas Conn. in.	F Floor to Space Heating Return in.	G Floor to Space Heating Outlet in.	H Floor to Heater Top in.	J Floor to Water Conn. in.	K Depth	Approx. Shipping Weight	
	U.S. Gal.	Imp. Gal.		Nat. BTU/Hr. Input	Nat. U.S. GPH											Nat. Imp. GPH
U-2-TW-50T6FRN	48	40	60,000	65	54	65 ⁷ / ₈	22	3	50 ¹ / ₈	11 ³ / ₄	13 ¹ / ₂	50 ¹ / ₈	56 ³ / ₈	57 ³ / ₄	26 ³ / ₄	184
U-2-TW-65T6FRN	65	54	60,000	65	54	69	24	3	53 ¹ / ₂	11 ³ / ₄	13 ¹ / ₂	53 ¹ / ₂	59 ¹ / ₂	60 ³ / ₄	28 ³ / ₄	215
U-2-TW-75T6RN	75	62	76,000	82	68	67 ³ / ₈	26	3	52	14	16 ³ / ₄	52	59 ¹ / ₄	60 ¹ / ₂	31	265

Model Number	Capacity		Recovery 50°C Rise*	A Floor to Vent Conn.		B Jacket Dia.	C Vent Size	D Floor to T&P Conn.	E Floor to Gas Conn. mm.	F Floor to Space Heating Return mm.	G Floor to Space Heating Outlet mm.	H Floor to Heater Top mm.	J Floor to Water Conn. mm.	K Depth	Approx. Shipping Weight
	Liters	Nat. kW Input		Nat. Liters/Hour	mm.										
U-2-TW-50T6FRN	182	17.6	246	1673	560	76	1273	298	343	1273	1432	1467	679	85	
U-2-TW-65T6FRN	246	17.6	246	1753	610	76	1360	298	343	1360	1511	1543	730	101	
U-2-TW-75T6RN	284	22.3	310	1711	660	76	1321	356	425	1321	1505	1537	787	120	

Available in Natural Gas only.

For 10 year models, change suffix from "6" to "10".

*Based on manufacturer's rated recovery efficiency.

110 V.A.C. Required for Power Venting / 110 V.A.C. 60HZ 3.1 Amperes.

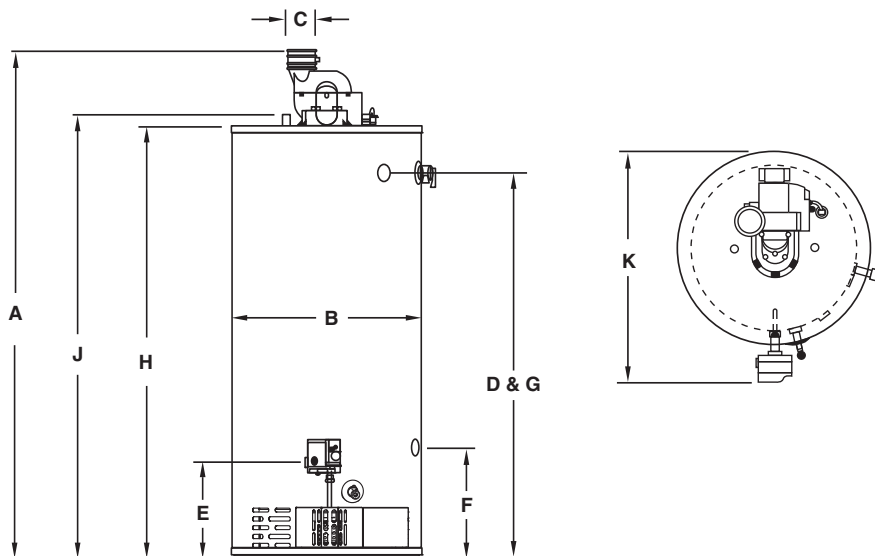

U-2-TW50 U-2-TW65 U-2-TW75	3" Vent Pipe	4" Vent Pipe
Max. Equivalent Length	†60 ft.**	†180 ft.
Min. Equivalent Length	7 ft.	15 ft.
Number of 90° Elbows	1 2 3	55 ft. 170 ft. 165 ft.

Subtract 5ft. for each additional 90° elbow
† For high altitude installations, consult the installation instructions.

** U-2-TW75 max. 3" vent length is 50 ft.

All models comply with the latest ultra-low NOx requirements of 10 ng/J or less.

Meets NAECA Requirements

General

All gas water heaters are certified at 300 PSI (2068 kPa) test pressure and 150 PSI (1034 kPa) working pressure.

All water connections are 3/4" NPT (19mm) on 11" (279mm) centers. All gas connections are 1/2" (13mm).

All models design certified by CSA International (formerly AGA/CGA), ANSI Z-21.10.1 (Z-21.10.3 for 75-gallon) and peak performance rated.

Dimensions and specifications subject to change without notice in accordance with our policy of continuous product improvement.

Suitable for Water (Potable) Heating and Space Heating

Toxic chemicals, such as those used for boiler treatment, shall NEVER be introduced into this system. This unit may NEVER be connected to any existing heating system or component(s) previously used with a non-potable water heating appliance.



For U.S. and Canada field service, contact your professional installer or local Bradford White sales representative.

Sales 800-523-2931 • Fax 215-641-1670 / Technical Support 800-334-3393 • Fax 269-795-1089 • Warranty 800-531-2111 • Fax 269-795-1089

International: Telephone 215-641-9400 • Telefax 215-641-9750 / www.bradfordwhite.com

BRADFORD WHITE-CANADA INC. Sales / Technical Support 866-690-0961 / 905-238-0100 • Fax 905-238-0105 / www.bradfordwhite.com

Built to be the Best™

©2014, Bradford White Corporation. All rights reserved.