

Residential Power Vent Gas Water Heater



Photo is of
RG2PV50H6N

FEATURING:



The TTW® Models Feature:

- **ENERGY STAR® Qualified**—Some models qualify for the September 1, 2010 minimum ENERGY STAR® EF requirement, as well as most utility rebate programs.
- **Bradford White ICON System™**—Intelligent gas control with spark to pilot ignition system eliminates the constant burning pilot. This results in savings of pilot gas during standby periods (120 V.A.C.).
 - **Enhanced Performance**—Proprietary algorithms provide enhanced First Hour Delivery ratings and tighter temperature differentials.
 - **Advanced Temperature Control System**—Microprocessor constantly monitors and controls burner operation to maintain consistent and accurate water temperature levels.
 - **Intelligent Diagnostics**—An exclusive green LED light prompts the installer during start-up and provides ten different diagnostic codes to assist in troubleshooting.
- **Power Vented Water Heater**—Designed for installations where atmospheric units cannot be used. Exhaust gases are vented under positive pressure directly out of the building through the roof or the wall.
- **Powerful Blower Motor**—Our significantly quiet design has greater resistance to outside winds and the power to vent in many difficult venting situations.
 - Ten Foot Power Cord—Included (120 VAC).
- **Horizontal and Vertical Venting**—PVC, ABS or CPVC (Maximum equivalent vent length on reverse side).
- **Advanced ScreenLok® Technology Flame Arrestor Design**—Flame arrestor is designed to prevent ignition of flammable vapor outside of the water heater (excluding RG1PV55H6N & RG2PV75H6N).
- **Flammable Vapor Sensor**—Electronic sensor prevents burner operation if flammable vapors are detected. The sensor will also prevent operation if there is ongoing flammable vapor burn inside the combustion chamber (excluding RG1PV55H6N & RG2PV75H6N).
- **Maintenance-Free**—No regular cleaning of air inlet openings or flame arrestor is required under normal conditions (excluding RG1PV55H6N & RG2PV75H6N).
- **Sight Window**—Offers a view into the combustion chamber to observe the operation of the pilot and burner.
- **Factory-Installed Hydrojet® Total Performance System**—Sediment reducing device that also increases first hour delivery of hot water while minimizing temperature build-up in tank.
- **Vitraglas® Lining**—An exclusively engineered enamel formula that provides superior tank protection from the highly corrosive effects of hot water. This formula (Vitraglas®) is fused to the steel surface by firing at a temperature of over 1600°F (871°C).
- **Insulation System**—Non-CFC foam covers the sides and top of the tank, reducing heat loss. This results in less energy consumption, improved efficiencies, and jacket rigidity.
- **Water Connections**—3/4" (19mm) NPT factory-installed true dielectric fittings extend water heater life and simplify water line connections.
- **3/4" (19mm) NPT Side Connections**—(RG2PV50H6N, RG1PV55H6N, and RG2PV75H6N only).
- **Factory-Installed Heat Traps**—Design incorporates a flexible disk that reduces heat loss in piping and eliminates the potential for noise generation.
- **Protective Magnesium Rod**—(RG1PV55H6N has 2).
- **T&P Relief Valve**—Installed.
- **Thermostatic Mixing Valve (ASSE Approved)**—Included (RG1PV55H6N only).
- **Low Restriction Brass Drain Valve**—Durable tamper-proof design.

6 or 10-Year Limited Tank Warranties / 6 or 10-Year Limited Warranty on Component Parts.

For more information on warranty, please visit www.bradfordwhite.com

For products installed in USA, Canada and Puerto Rico. Some states do not allow limitations on warranties. See complete copy of the warranty included with the heater.

Residential Power Vent Gas Water Heater

Power Vent Models

NATURAL GAS AND LIQUID PROPANE GAS

Meet or exceed ASHRAE 90.1b (current standard) C.E.C. Listed
80% Recovery Efficiency

Model Number	Capacity		Nat. BTU/Hr. Input	LP BTU/Hr. Input	1st Hour Rating (Gal.)	Energy Factor	Recovery at 90°F Rise*				Model Number	Capacity		Nat. kW Input	LP kW Input	1st Hour Rating (Liters)	Energy Factor	Recovery at 50°C Rise*	
	U.S. Gal.	Imp. Gal.					Nat. U.S. GPH	Nat. U.S. GPH	LP U.S. GPH	LP U.S. GPH		Liters	Imp. Liters/ Hour					LP Liters/ Hour	
RG1PV40S6N	40	33	40,000	38,000	72	0.66	43	36	41	34	RG1PV40S6N	151	11.7	11.1	273	0.66	163	155	
RG1PV50S6N	50	42	40,000	38,000	86	0.65	43	36	41	34	RG1PV50S6N	189	11.7	11.1	326	0.65	163	155	
★ RG2PV40S6N	40	33	40,000	38,000	72	0.67	43	36	41	34	★ RG2PV40S6N	151	11.7	11.1	273	0.67	163	155	
★ RG2PV50S6N	50	42	40,000	38,000	84	0.67	43	36	41	34	★ RG2PV50S6N	189	11.7	11.1	326	0.67	163	155	
★ RG2PV40T6N	40	33	40,000	40,000	72	0.70	43	36	43	36	★ RG2PV40T6N	151	11.7	11.7	273	0.70	163	163	
★ RG2PV50T6N	50	42	40,000	40,000	86	0.70	43	36	43	36	★ RG2PV50T6N	189	11.7	11.7	326	0.70	163	163	
★ RG2PV50H6N	48	42	65,000	58,000	112	0.70	70	58	62	52	★ RG2PV50H6N	182	19.1	17.0	424	0.70	265	235	
RG1PV55H6N	55	46	78,000	78,000	N/A	N/A	84	70	84	70	RG1PV55H6N	208	22.9	22.9	N/A	N/A	318	317	
RG2PV75H6N	75	62	76,000	75,500	N/A	N/A	82	68	81	67	RG2PV75H6N	284	22.3	22.1	N/A	N/A	310	307	

Model Number	A Floor to Vent Conn. in.	B Jacket Dia. in.	C Vent Size in.	D Floor to T&P Conn. in.	E Floor to Gas Conn. in.	F Floor to Top of Heater in.	H C/L of Water Conn. in.	J Floor to Water Conn. in.	K Depth in.	L Floor to Space Heating Inlet in.	M Floor to Space Heating Outlet in.	Approx. Shipping Weight lbs.
RG1PV40S6N	57 ⁵ / ₁₆	20	2 or 3	40	11 ³ / ₄	47 ¹ / ₂	8	49	24 ³ / ₄	N/A	N/A	140
RG1PV50S6N	58 ¹ / ₄	22	2 or 3	40 ⁵ / ₈	11 ³ / ₄	48 ¹ / ₄	8	50 ¹ / ₂	26 ³ / ₄	N/A	N/A	166
★ RG2PV40S6N	57 ⁵ / ₁₆	22	2 or 3	40	11 ³ / ₄	47 ¹ / ₂	8	49	26 ³ / ₄	N/A	N/A	142
★ RG2PV50S6N	58 ¹ / ₄	24	2 or 3	40 ⁵ / ₈	11 ³ / ₄	48 ¹ / ₄	8	50 ¹ / ₂	28 ³ / ₄	N/A	N/A	168
★ RG2PV40T6N	66 ⁷ / ₈	20	2 or 3	50	11 ³ / ₄	56 ³ / ₄	8	58	24 ³ / ₄	N/A	N/A	146
★ RG2PV50T6N	66 ⁷ / ₈	22	2 or 3	50	11 ³ / ₄	56 ³ / ₄	8	58	26 ³ / ₄	N/A	N/A	173
★ RG2PV50H6N	66 ¹ / ₈	22	3 or 4	50 ¹ / ₈	11 ³ / ₄	56 ³ / ₈	11	57 ³ / ₄	26 ³ / ₄	13 ¹ / ₂	50 ¹ / ₈	187
RG1PV55H6N	64 ³ / ₁₆	22	3 or 4	47 ¹⁵ / ₁₆	11 ¹ / ₂	54 ⁵ / ₈	8	56	26 ³ / ₄	13 ³ / ₈	47 ¹⁵ / ₁₆	219
RG2PV75H6N	69 ⁷ / ₁₆	26	3 or 4	51 ¹ / ₂	13 ¹ / ₂	59 ¹ / ₂	11	60 ³ / ₄	30 ³ / ₄	13 ³ / ₈	51 ¹ / ₂	260

Model Number	A Floor to Vent Conn. mm.	B Jacket Dia. mm.	C Vent Size mm.	D Floor to T&P Conn. mm.	E Floor to Gas Conn. mm.	F Floor to Top of Heater mm.	H C/L of Water Conn. mm.	J Floor to Water Conn. mm.	K Depth mm.	L Floor to Space Heating Inlet mm.	M Floor to Space Heating Outlet mm.	Approx. Shipping Weight kg.
RG1PV40S6N	1456	508	51 or 76	1016	298	1207	203	1245	629	N/A	N/A	64
RG1PV50S6N	1480	559	51 or 76	1032	298	1226	203	1283	679	N/A	N/A	75
★ RG2PV40S6N	1456	559	51 or 76	1016	298	1207	203	1245	679	N/A	N/A	64
★ RG2PV50S6N	1480	610	51 or 76	1032	298	1226	203	1283	730	N/A	N/A	76
★ RG2PV40T6N	1699	508	51 or 76	1270	298	1441	203	1473	629	N/A	N/A	66
★ RG2PV50T6N	1699	559	51 or 76	1270	298	1441	203	1473	679	N/A	N/A	78
★ RG2PV50H6N	1680	559	76 or 102	1273	298	1432	279	1467	679	343	1273	85
RG1PV55H6N	1630	559	76 or 102	1218	279	1388	203	1422	679	340	1218	99
RG2PV75H6N	1764	660	76 or 102	1308	343	1511	279	1543	781	340	1308	118

Propane models feature a Titanium Stainless Steel propane burner. For Propane (LP) models change suffix "N" to "X". For 10 year models, change suffix from "6" to "10" (Not available on RG1PV55H6N). *Based on manufacturer's rated recovery efficiency. 120 VAC Required for Power Venting / 120 VAC 60HZ 3.1 Amperes. Energy Factor and First Hour Rating is based on the latest AHRI directory listings.

★ = ENERGY STAR® Qualified.



RG2PV40S6N	RG1PV50S6N	2" Vent Pipe	3" Vent Pipe	RG2PV50H6N	RG1PV55H6N	3" Vent Pipe	4" Vent Pipe
Max. Equivalent Length	†50 ft.	†120 ft.		Max. Equivalent Length	†50 ft.	†180 ft.	
Min. Equivalent Length	7 ft.	15 ft.		Min. Equivalent Length	7 ft.	15 ft.	
Number of 90° Elbows	1	45 ft.	115 ft.	Number of 90° Elbows	1	45 ft.	175 ft.
	2	40 ft.	110 ft.		2	40 ft.	170 ft.
	3	35 ft.	105 ft.		3	35 ft.	165 ft.

Subtract 5ft. for each additional 90° elbow

† For high altitude installations, consult the installation instructions.

General: All gas water heaters are certified at 300 PSI (2068 kPa) test pressure and 150 PSI (1034 kPa) working pressure. All water connections are 3/4" NPT (19mm), all gas connections are 1/2" (13mm). All models design-certified by CSA International (formerly AGA/CGA), ANSI Z-21.10.1 and/or 10.3 and peak performance rated.

Dimensions and specifications subject to change without notice in accordance with our policy of continuous product improvement.

Suitable for Water (Potable) Heating and Space Heating. Toxic chemicals, such as those used for boiler treatment, shall NEVER be introduced into this system. This unit may NEVER be connected to any existing heating system or component(s) previously used with a non-potable water heating appliance.

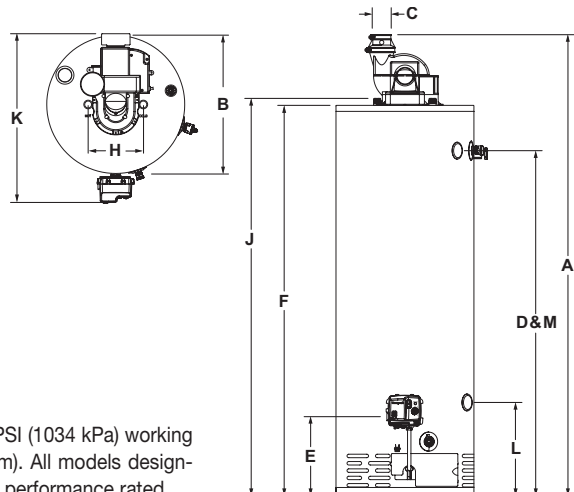

For U.S. and Canada field service, contact your professional installer or local Bradford White sales representative.

Sales 800-523-2931 • Fax 215-641-1670 / Technical Support 800-334-3393 • Fax 269-795-1089 • Warranty 800-531-2111 • Fax 269-795-1089

International: Telephone 215-641-9400 • Telefax 215-641-9750 / www.bradfordwhite.com



Sales / Technical Support 866-690-0961 / 905-238-0100 • Fax 905-238-0105 / www.bradfordwhite.com

Built to be the Best™